

AUTOMATIC RIFLE

HK 33

Caliber 5.56 mm x 45 Nato



HK

HECKLER & KOCH GMBH

OBERNDORF/NECKAR

GERMANY

**TECHNICAL DESCRIPTION
OF THE
AUTOMATIC RIFLE HK 33**

Part 1: Description of the Weapon and Accessories

Part 2: Operating Instructions and Maintenance

This is not an official manual. Under no circumstances shall the reader contact the manufacturer regarding any data presented in this pamphlet.



HECKLER & KOCH GMBH

OBERNDORF/NECKAR

GERMANY

TABLE OF CONTENTS

1.	Description of the weapon	Page
1.1.	General information	1
1.1.1.	Designation	1
1.1.2.	Applications	1
1.1.3.	General description	1
1.2.	General illustrations	2
1.3.	Assembly groups	4
1.3.1.	Assembly groups - Rifle HK 33	4
1.3.2.	Assembly groups - Rifle HK 33 K	4
1.4.	Technical data	5
1.5.	Technical description	6
1.5.1.	Construction	6
1.5.1.1.	Barrel with receiver, cocking lever mechanism and sights	7
1.5.1.2.	Bolt assembly	12
1.5.1.3.	Grip assembly with trigger and safety mechanism	14
1.5.1.4.	Butt stock	15
1.5.1.4.1.	Rigid butt stock	15
1.5.1.4.2.	Retractable butt stock	16
1.5.1.5.	Handguard	17
1.5.1.6.	20-Round magazine	17
1.5.1.7.	Scopes	18
1.5.1.7.1.	Telescopic sight with mount	18
1.5.1.7.2.	Infrared scope with mount	19
1.5.1.8.	Training equipment	20
1.5.1.8.1.	Blank attachment	20
1.5.1.8.2.	Subcalibre conversion kit for .22 LR (5.6 mm x 16) ammunition	21
1.5.2.	Operation	25
1.5.2.1.	Bolt Assembly	25
1.5.2.2.	Bolt assembly for .22 LR (5.6 mm) ammunition	27
1.5.2.3.	Trigger mechanism	28
1.5.2.3.1.	Initial position at "S" - Safe	28
1.5.2.3.2.	Function in position "E" - single fire	29
1.5.2.3.3.	Function in position "F" - burst	33
1.6.	Equipment	34
1.6.1.	Accessories	34

2.	Instructions for use including Maintenance	Page
2.1.	Instructions for use	35
2.1.1.	Principles of handling and use	35
2.1.2.	Preparing the rifle for firing	35
2.1.2.1.	Cocking	35
2.1.2.2.	Firing	36
2.1.2.3.	Uncocking	36
2.1.2.4.	Filling and emptying the magazine	37
2.1.2.5.	Launching rifle grenades	37
2.1.2.6.	Firing with training equipment	38
2.1.2.6.1.	Blank attachment	38
2.1.2.6.2.	Subcalibre conversion kit for .22 (5.6 mm x 16) ammunition	39
2.1.3.	Using the rifle with scopes	39
2.1.3.1.	Telescopic sight with mount	39
2.1.3.2.	Infrared scope with mount	41
2.1.4.	Using the rifle under extreme climatic conditions	41
2.2.	Maintenance	42
2.2.1.	General	42
2.2.2.	Stripping and assembling the rifle and the training equipment for cleaning	42
2.2.3.	Maintenance plan	49
2.2.4.	Special notes regarding maintenance products and equipment	50
2.2.5.	Maintenance instructions	50
2.2.5.1.	Major cleaning	50
2.2.5.2.	Normal cleaning	50
2.2.6.	Functional test	51
2.2.6.1.	Magazine	51
2.2.6.2.	Cocking procedure	51
2.2.6.3.	Safety	51
2.2.6.4.	Trigger mechanism	51
2.2.7.	Trouble-shooting chart	52

1.1. General Information

1.1.1. Designation

Rifle HK 33, calibre 5.56 mm x 45



Fig. 1: Rifle HK33

1.1.2. Applications

The Rifle HK33 is an automatic small arm which can fire single shots or bursts from all firing positions.

1.1.3. General Description

The Rifle HK33 is a recoil operated weapon incorporating a delayed roller locked bolt system. Ammunition is fed from a 20 or 40 round magazine or can be inserted manually.

Telescopic sights or Infrared scopes can be employed without modifying the rifle. Rifle grenades can be launched with the rifle. Required for this is a 5.56 mm x 45 propellant cartridge. A blank attachment permits 5.56 mm x 45 blank ammunition to be fired.

The subcalibre conversion kit is a training accessory for the Rifle HK33, thus making possible the use of 5.6 mm x 16 ammunition.

1.2. General Illustrations



Fig. 2: HK33 from the left



Fig. 3: HK33 from the right

Rifle HK33 with rigid butt stock and magazine for 20 cartridges.



Fig. 4: HK33A1 from the left



Fig. 5: HK33A1 from the right

Rifle HK33A1 with retractable butt stock and magazine for 40 cartridges.



Fig. 6: HK33ZF from the left



Fig. 7: HK33ZF from the right
Rifle HK33 with telescopic sight



Fig. 8: HK33K from the left



Fig. 9: HK33K from the right
Rifle HK33K with retracted butt stock and magazine for 40 cartridges.

1.3. Assembly Groups

1.3.1. Assembly Groups - Rifle HK33

- | | | | |
|---|--|---|----------------------------|
| 1 | Barrel with receiver | 4 | Butt stock |
| 2 | Bolt | 5 | Handguard |
| 3 | Grip assembly with trigger and safety mechanisms | 6 | Magazine for 20 cartridges |

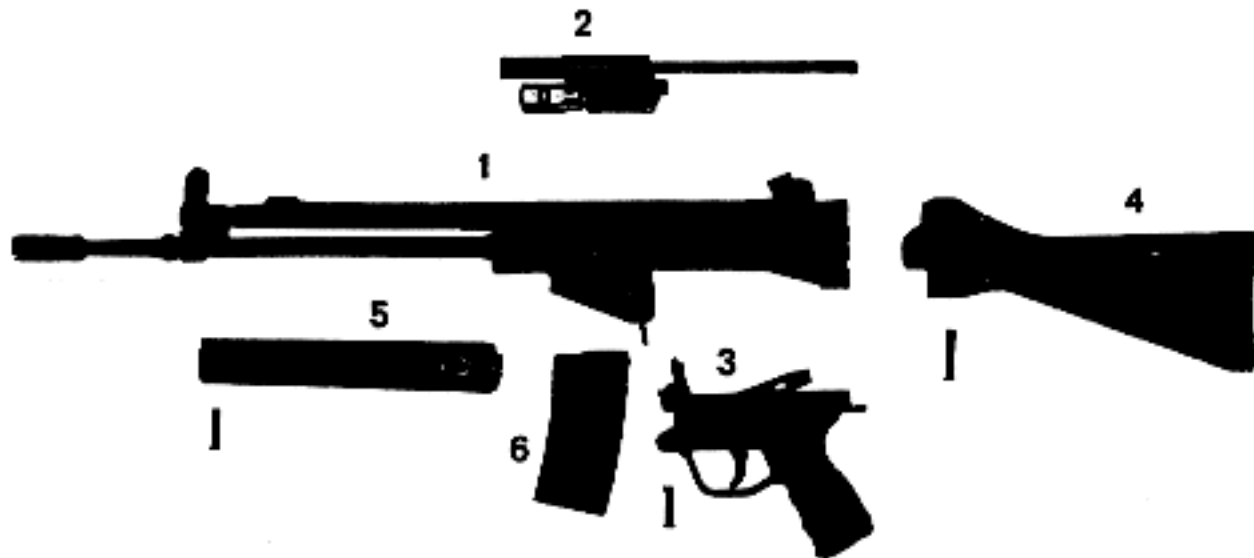

Fig. 10: Assembly groups

1.3.2. Assembly Groups - Rifle HK33K

- | | | | |
|---|--|---|----------------------------|
| 1 | Barrel with receiver | 4 | Retractable butt stock |
| 2 | Bolt | 5 | Handguard |
| 3 | Grip assembly with trigger and safety mechanisms | 6 | Magazine for 20 cartridges |



Fig. 11: Assembly groups

1.4. Technical Data

Rifle HK33, HK33A1 and HK33K

General

Operating principle	recoil-operated
Locking system	delayed, roller locked
Feed device	20 and 40 round arc-shaped magazine
Twist	constant right-hand
Number of grooves	6
Number of flutes	16
Distance between bolt head and bolt head carrier	0.1 - 0.5 mm
Type of fire	single shots and bursts
Rate of fire	approx. 600 - 650 r. p. m.
Sights, mechanical	diopter rotary rear sight with 4 adjustments; "V"-sight; 200, 300 and 400 m aperture sight; adjustable for windage and elevation scope
Sights, optical	4 power, 6 adjustments from 100 to 600 m; adjustable for windage and elevation
Calibre	5.56 mm x 45 (.223)
Muzzle velocity - V_0 - HK 33 and HK33A1 HK33K	approx. 3150 f. p. s. (960 m/s) approx. 3018 f. p. s. (920 m/s)
Muzzle energy - E_0 - HK33 and HK33A1 HK33K	approx. 1210 ft. lb. (167 mkp) approx. 1105 ft. lb. (153 mkp)
Lengths	
Rifle HK33	36.22 in. (920 mm)
Rifle HK33A1	
Butt stock retracted	29.52 in. (750 mm)
Butt stock extracted	36.22 in. (920 mm)
Rifle HK33K	
Butt stock retracted	26.37 in. (670 mm)
Butt stock extracted	34.05 in. (865 mm)
Sight radius	18.88 in. (480 mm)
Barrel	
Rifle HK33 and HK33A1	15.35 in. (390 mm)
Rifle HK33K	12.67 in. (322 mm)

Weights

Rifle HK33, without magazine	7.38 lbs. (3.35 kp)
Rifle HK33A1, without magazine	7.60 lbs. (3.45 kp)
Rifle HK33K, without magazine	8.16 lbs. (3.70 kp)
Aluminium magazine, empty, taking 20 cartridges	4.05 oz. (0.11 kp)
Aluminium magazine, empty, taking 40 cartridges	5.65 oz. (0.16 kp)
Cartridge	1.70 grs. (11 p)

1.5. Technical Description

1.5.1. Construction

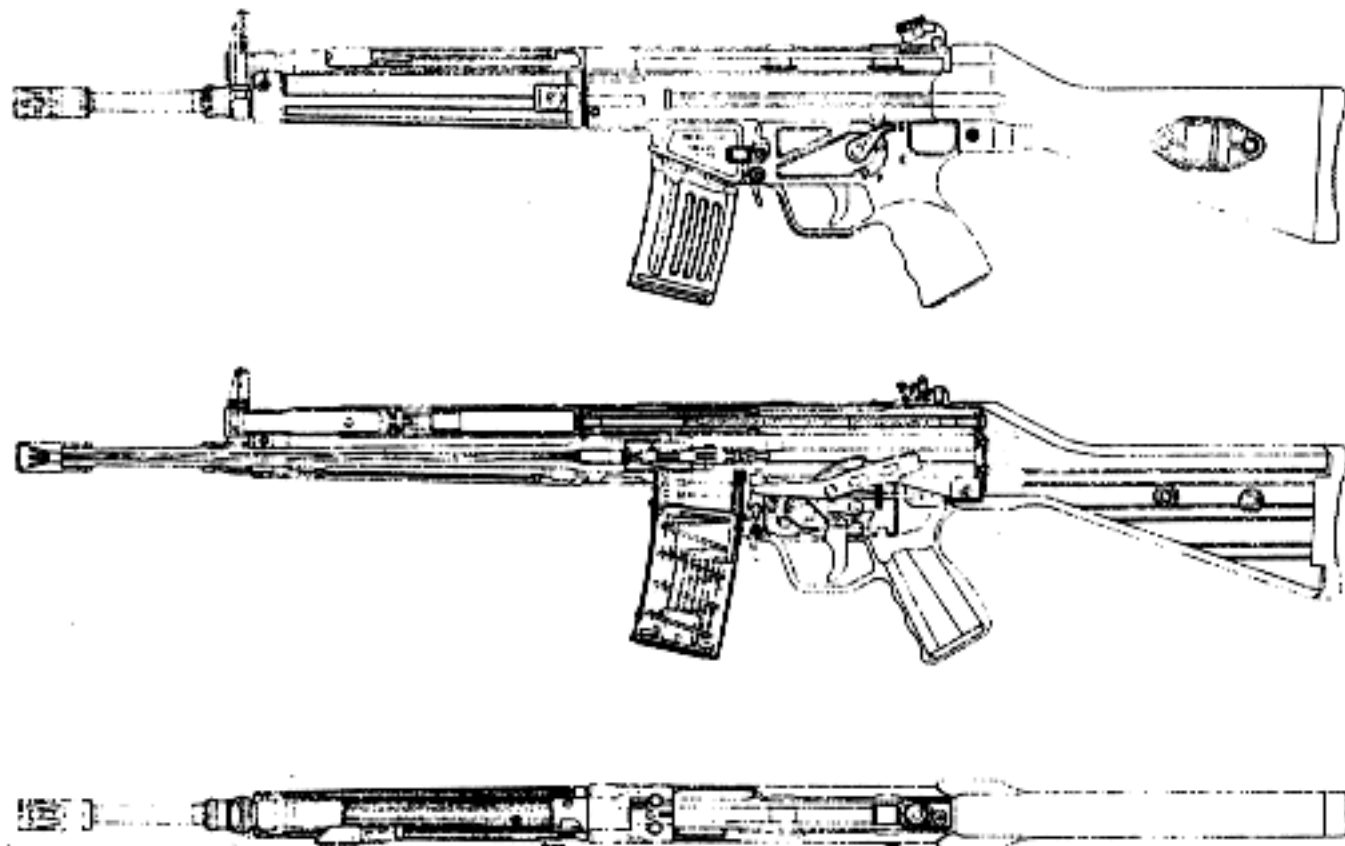

Fig. 12: Sectional view of the Rifle HK33

1.5.1.1. Barrel with Receiver, Cocking Lever Mechanism and Sights

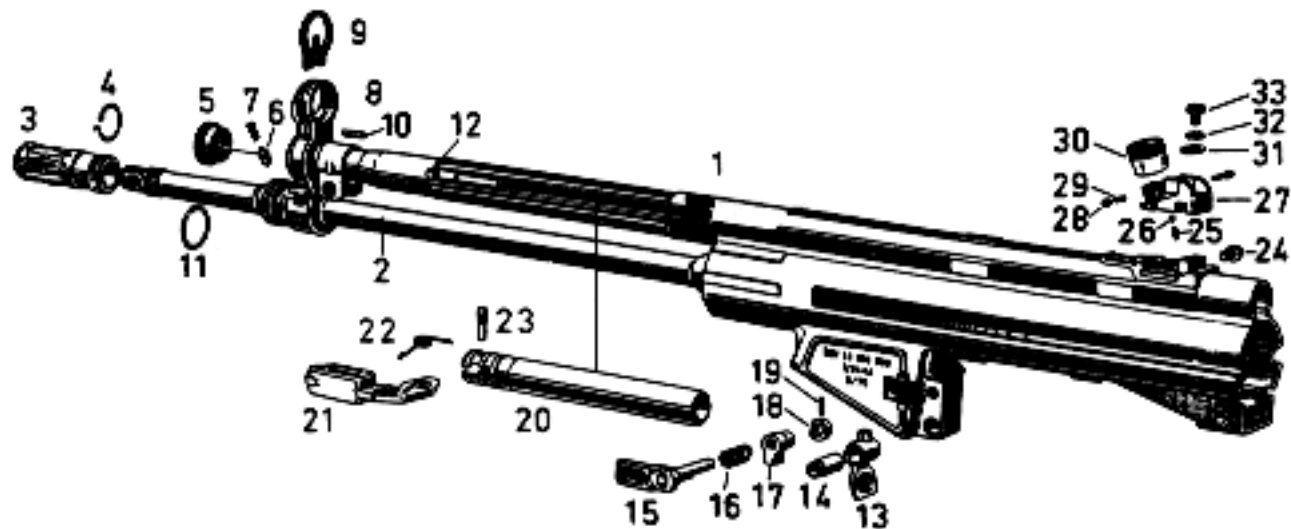

Fig. 13: Barrel with receiver cocking lever mechanism and sights

- | | | | |
|----|--|----|-----------------------------------|
| 1 | Barrel with receiver, cocking lever and front sight holder | 17 | Contact piece for magazine catch |
| 2 | Barrel | 18 | Push button |
| 3 | Flash suppressor | 19 | Clamping sleeve |
| 4 | Retaining spring | 20 | Cocking lever support |
| 5 | Cap | 21 | Cocking lever |
| 6 | Compression bolt | 22 | Elbow spring for cocking lever |
| 7 | Compression spring | 23 | Axle for cocking lever |
| 8 | Front sight holder | 24 | Adjusting screw |
| 9 | Front sight | 25 | Compression spring for ball notch |
| 10 | Retaining pin | 26 | Ball |
| 11 | Spring ring | 27 | Sight support |
| 12 | Rivet | 28 | Catch bolt |
| 13 | Magazine release lever | 29 | Spring for catch bolt |
| 14 | Bush for magazine release lever | 30 | Sight drum |
| 15 | Magazine catch | 31 | Fix plate |
| 16 | Compression spring | 32 | Lock washer |
| | | 33 | Binding screw |

The receiver (14/1) connects barrel (14/2), cocking lever mechanism (14/4) and sights (14/6).

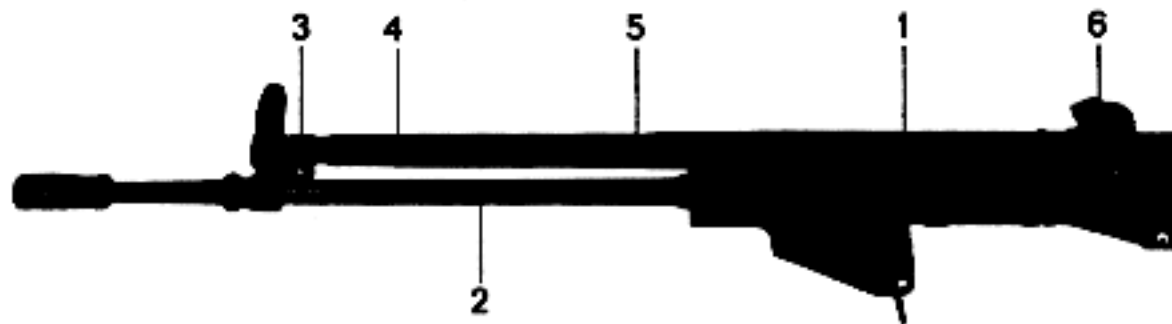

Fig. 14: Barrel with receiver, cocking lever mechanism and sights

Pressed into the right and left sides of the receiver are rails to guide the bolt. In front are the openings for the barrel extension and barrel as well as the cocking lever housing (14/5).

The rear of the receiver is closed by the back plate. The lower rear section of the receiver is box-shaped and has one hole in which is inserted the locking pin which connects the back plate and the grip assembly to the receiver.

In the front of the receiver are the magazine well with magazine release lever and the hole with bush for the grip assembly locking pin. The magazine well receives the magazine in conjunction with the magazine catch (13/15).

On the right side of the receiver is the ejection port. The sight base is welded to the receiver.

The extension of the rear sight base serves to locate the telescopic sight mount.

On the left and right sides of the receiver are 4 raised areas for engaging the clamping claws of the telescopic sight mount.

The cocking lever housing is inserted in the receiver and welded in place. Welded to the front of the cocking lever housing is a U-clamp (14/3) for holding the handguard locking pin.

On the left side of the cocking lever housing is a slot with a recess at the top rear for engaging the cocking lever (13/21). The cocking lever with elbow spring (12/22) and cocking lever support (13/20) slide in the cocking lever housing. The bolt is drawn back by means of the cocking lever, compressing the recoil spring. The support and the cocking lever are limited in front by the stop abutment. The stop abutment is connected to the cocking lever housing by means of a rivet (13/12). This rivet protrudes on the left side as a pin. The cocking lever engages this pin when the bolt snaps forward. The front end of the cocking lever housing is closed by a cap (13/5); a set bolt (13/6) with spring (13/7) holds the cap at place in the front sight holder (13/8).

Barrel

In the barrel, the cartridge is ignited and the bullet is given motion, direction and twist. The interior of the barrel consists of the chamber (15/1) and the rifled section (15/2). In the rifled section are 6 grooves, which have a constant right-hand twist.

The grooves can either be cut, drawn or hammered.



Fig. 15: Barrel

The chamber has 16 flutes, which facilitate the extraction of the cartridge case by means of the gas pressure. The muzzle is threaded (15/5) for screwing on the flash suppressor or blank attachment when these are screwed on.

The longitudinal grooves (15/3) milled behind the centering shoulder serve to retain the spring on the flash suppressor or the blank attachment.

Flash Suppressor

Almost all of the powder gases still burning as they leave the muzzle are extinguished by the longitudinal slots (16/1) of the flash suppressor, thus almost entirely reducing the muzzle flash. The suppressor also serves as a guide for launching rifle grenades.

The retaining spring (16/2) at the rear engages in the longitudinal grooves at the barrel shoulder and prevents the flash suppressor or blank attachment from working loose. The flash suppressor must be threaded tightly to the barrel.



Fig. 16: Flash suppressor

Sights

The sights are comprised of the fixed front sight in the front sight holder (17/1) and the vertically and horizontally adjustable rotary rear sight (17/2).

The rotary rear sight with V-notch and diopter holes can be set in positions 1 to 4. Position "1" is an open V-sight, while positions "2, 3 and 4" are aperture sights. Positions "2, 3 and 4" correspond to ranges of 200, 300 and 400 metres.

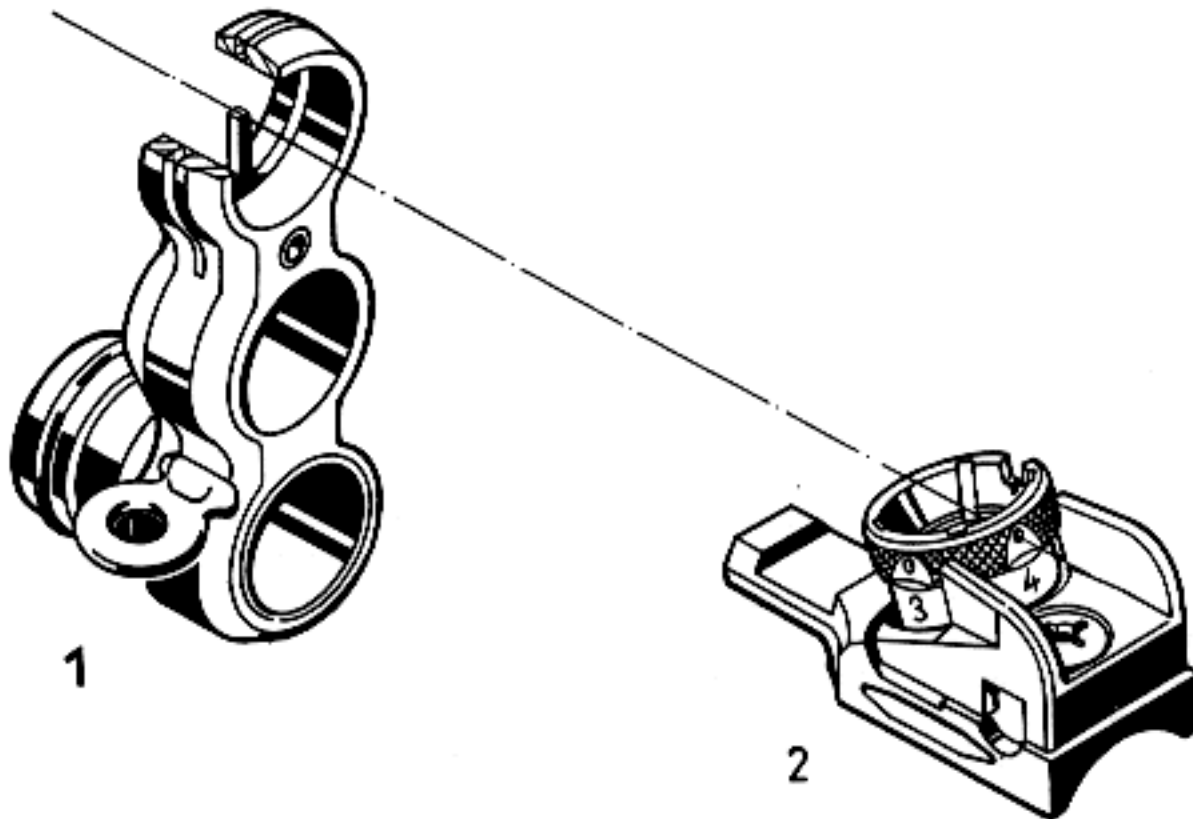

Fig. 17: Sights

The front sight holder (18/1) with front sight holder bush (18/2) is inserted over the barrel and soldered in place. In addition, the front sight holder is secured to the barrel by means of the eyebolt (18/3). The spring hook on the sling is attached to this eyebolt. The snap ring (18/4) at the front of the front sight holder provides a secure seat for the grenade. The upper section of the front sight holder is designed as a front sight hood. The front sight (18/5) is inserted into a lateral slot and secured by means of a retaining pin (18/6).

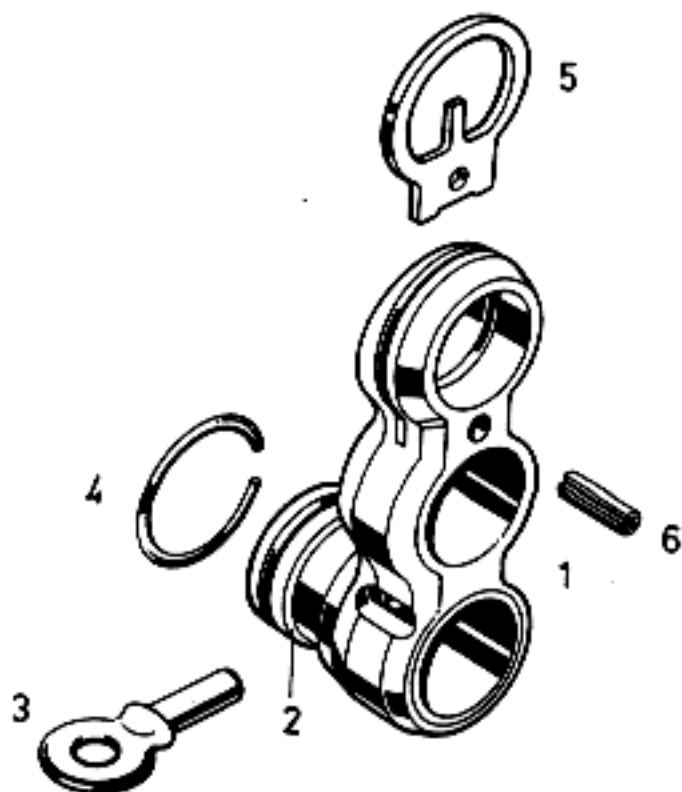

Fig. 18: Front sight holder

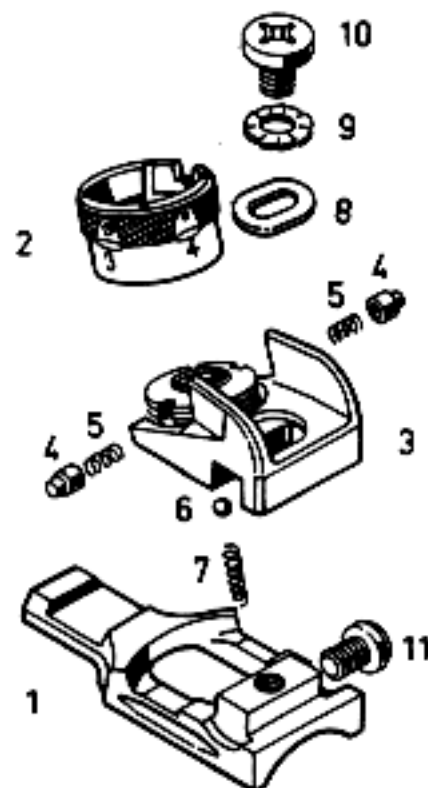

Fig. 19: Rotary rear sight

The rear sight base (19/1) is welded to the receiver, and the sight cylinder (19/2) is screwed to the sight support (19/3). The two catch bolts (19/4) and catch bolt springs (19/5) are located between the rotating threaded ring in the sight support and the sight cylinder. The ball (19/6) and compression spring (19/7) press against the threaded ring and lock the sight cylinder in the desired sight adjustment. The sight support is screwed to the rear sight base by means of fix plate (19/8), lock washer (19/9) and binding screw (19/10). The rear sight is adjusted laterally by means of the adjusting screw (19/11).

1.5.1.2. Bolt Assembly

- | | |
|------------------------------|-----------------------------|
| 1 Bolt head carrier | 13 Firing pin |
| 2 Cylindrical pin | 14 Slide |
| 3 Locking lever | 15 Buffer bolt |
| 4 Compression spring | 16 Brake ring |
| 5 Bolt head | 17 Disc |
| 6 Extractor spring | 18 Buffer springs |
| 7 Extractor | 19 Recoil spring |
| 8 Cylindrical pin | 20 Recoil spring guide rod |
| 9 Holder for locking rollers | 21 Recoil spring guide ring |
| 10 Locking rollers | 22 Stop pin |
| 11 Locking piece | 23 Rivet |

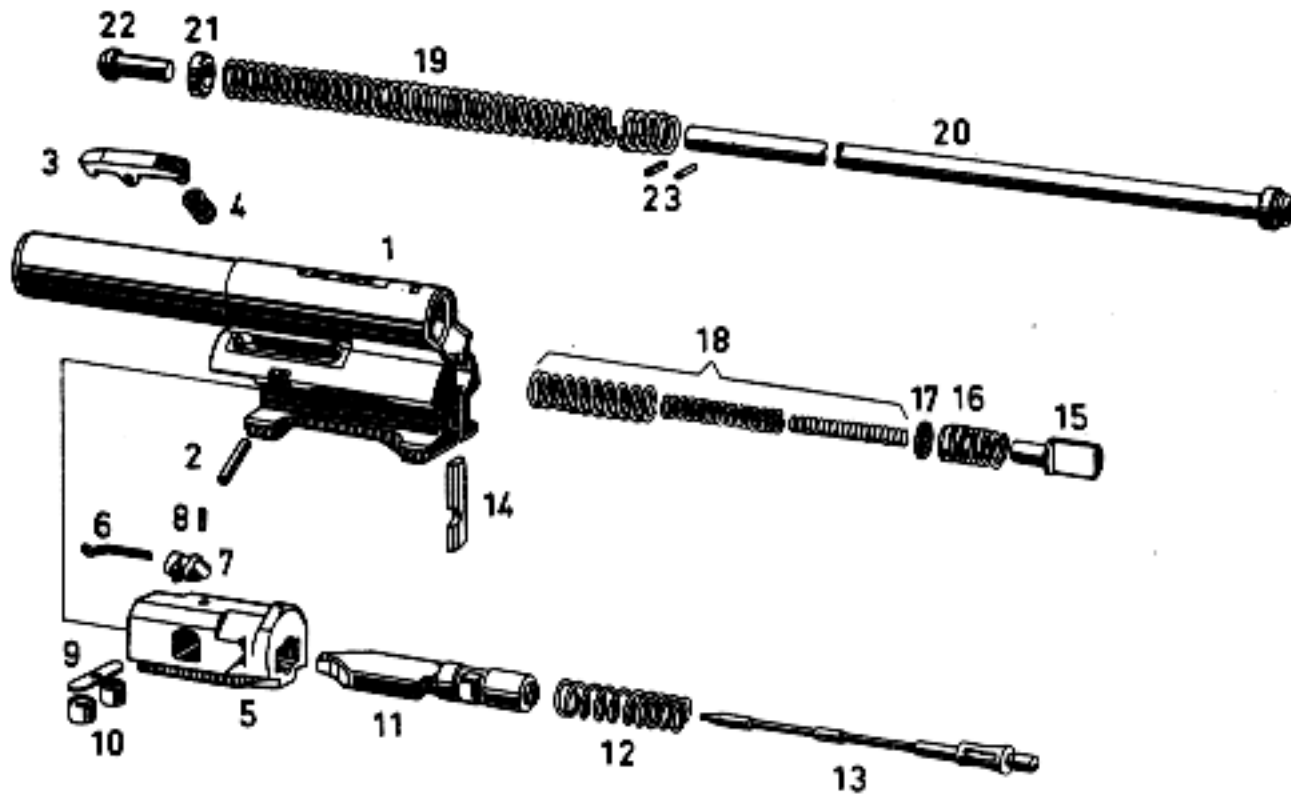

Fig. 20: Bolt assembly

The bolt assembly is located in the receiver and together with the cartridge case, seals the rear of the chamber when firing. It also feeds and fires the round, extracts and ejects the empty cartridge case and cocks the hammer.

The bolt head carrier (20/1) carries the bolt head (20/5). It has studs on both sides, permitting it to slide in the guide rails of the receiver. Located in its longitudinal bore are the firing pin (20/13) with firing pin spring (20/12) and the locking piece (20/11). The bolt head is located in the open front of the bolt head carrier. At the top left of the bolt head carrier is the locking lever (20/3) with cylindrical pin (20/2) and compression spring (20/4). The nose of the locking lever engages the bolt head at the moment of locking, preventing the separation of bolt head and bolt head carrier. The buffer assembly (20/15-18) in the bolt head carrier absorbs after firing the remaining energy of the recoiling bolt and brings it in connection with the recoil spring in front position again.

The recoil spring tube of the bolt head carrier contains the recoil spring (20/19) with recoil spring guide rod (20/20). The bolt head and locking piece are seated in the bolt head carrier and are held at the shoulder of the bolt head by the locking lever. It is bored and milled to guide the front section of the locking piece, the firing pin and the locking rollers (20/10) with the roller holder (20/9). The bottom of the bolt head is rib-shaped. In it are a longitudinal groove for the ejector and recesses to provide free access to the lips of the magazine. The semi-circular shoulder at the rear limits the longitudinal movement of the inserted bolt head.

The extractor (20/7) is located on the face the bolt head. It is held elastically by the extractor spring (20/6). It grasps the extractor groove at the base of the cartridge case with its extracting claw.

The locking piece regulates the displacement of the locking rollers thus controlling the locking and unlocking of the bolt head in the barrel extension. Its flattened front section slides in the bolt head; its cylindrical rear section has a cam which holds it in the bolt head carrier. Its longitudinal axle has a bore for guiding the firing pin.

The firing pin ignites the cartridge. It is guided in the bolt head, locking piece and bolt head carrier. Its shoulder serves as an abutment for the firing pin spring.

1.5.1.3. Grip Assembly with Trigger and Safety Mechanism

- 1 Grip
- 2 Trigger assembly housing
- 3 Locking pin
- 4 Safety mechanism

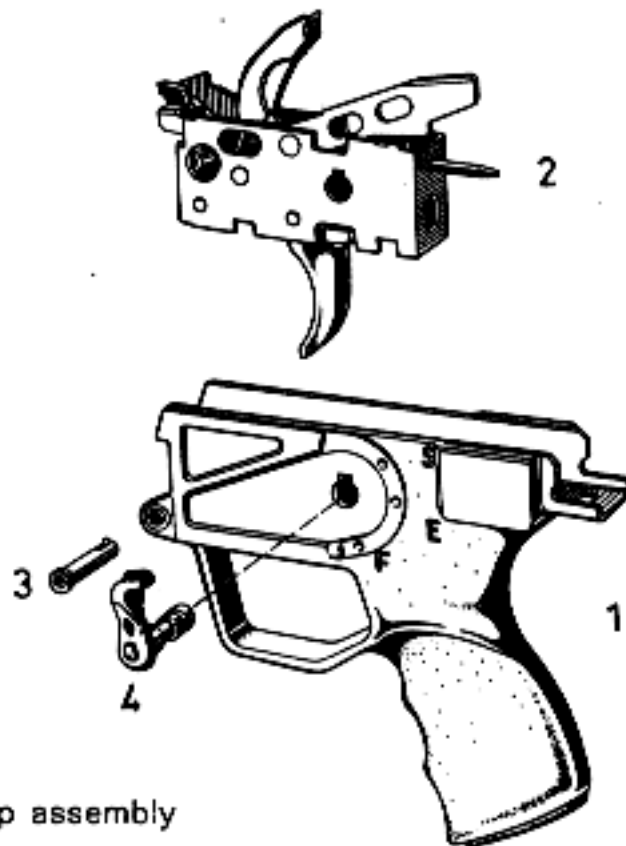

Fig. 21: Grip assembly

The grip (21/1) contains the trigger assembly housing (21/2) and is connected to the receiver by means of the locking pin (21/3). The safety pin (21/4) fixes the trigger assembly housing in the grip assembly. On the left side of the grip assembly, the selective fire lever can be set at:

- S = safe (white)
- E = single fire (red)
- F = burst (red)

A white mark on the face of the safety pin also indicates the position of the selective fire lever from the right side of the grip assembly.



Fig. 22: Safety mechanism - left side of weapon

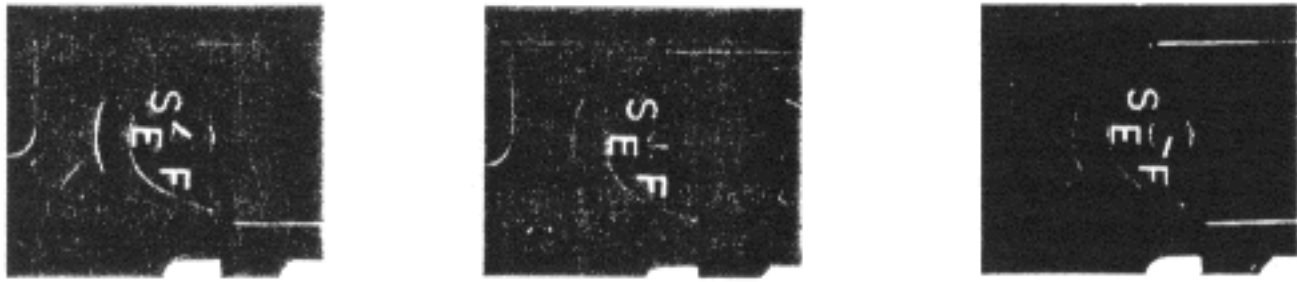
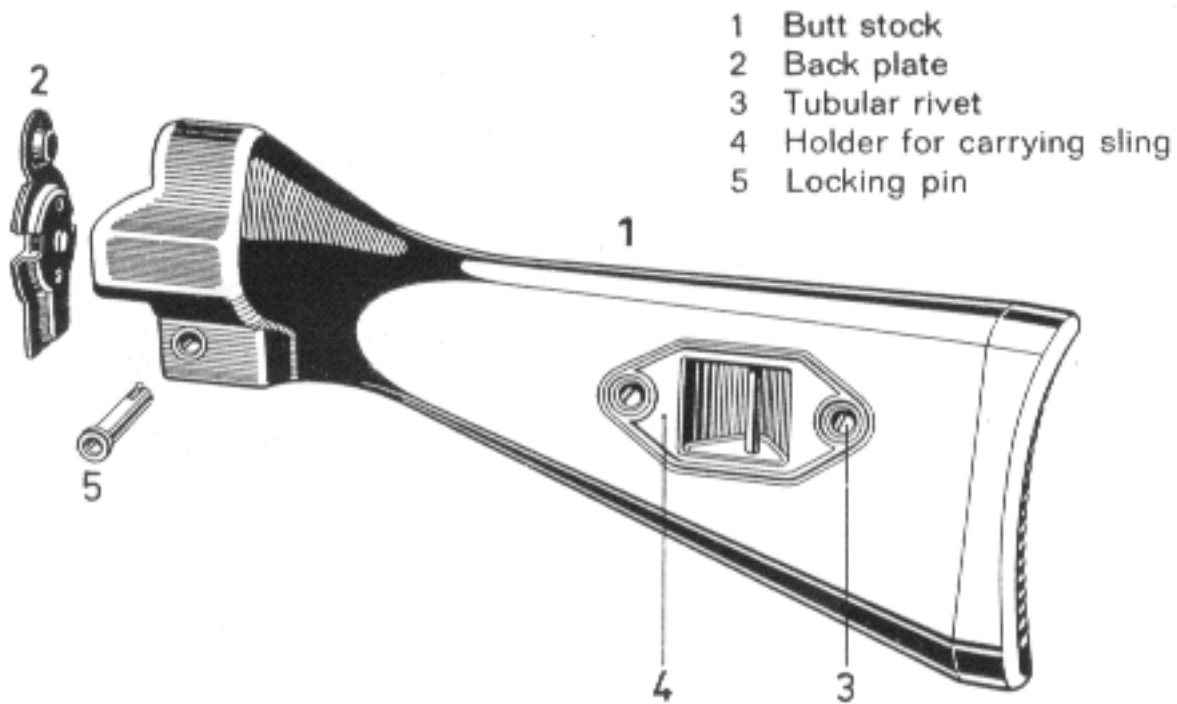

Fig. 23: Safety mechanism - right side of weapon

The trigger assembly housing (21/2) contains all components of the trigger mechanism.

1.5.1.4. **Butt Stock**

1.5.1.4.1. **Rigid Butt Stock**



- 1 Butt stock
- 2 Back plate
- 3 Tubular rivet
- 4 Holder for carrying sling
- 5 Locking pin

Fig. 24: Rigid butt stock

The butt stock with back plate closes the rear of the receiver. It is connected to the receiver by means of one locking pin (24/6).

The butt stock (24/1) aids in handling the rifle and in positioning it against the shooter's shoulder. Recessed in the left side of the butt stock is the sling holder. The tubular rivets (24/3) are used for storing the locking pin while stripping the rifle.

1.5.1.4.2. Retractable Butt Stock

- | | | | |
|---|--------------------|----|--------------------|
| 1 | Back plate | 7 | Cover with plug |
| 2 | Buffer screw | 8 | Tension lever |
| 3 | Compression bolt | 9 | Tension spring |
| 4 | Compression spring | 10 | Locking ring |
| 5 | Clamping sleeve | 11 | Catch spring |
| 6 | Gripping lever | 12 | Lock |
| | | 13 | Compression spring |
| | | 14 | Clamping sleeve |
| | | 15 | Spring ring |
| | | 16 | Butt stock |
| | | 17 | Locking pin |

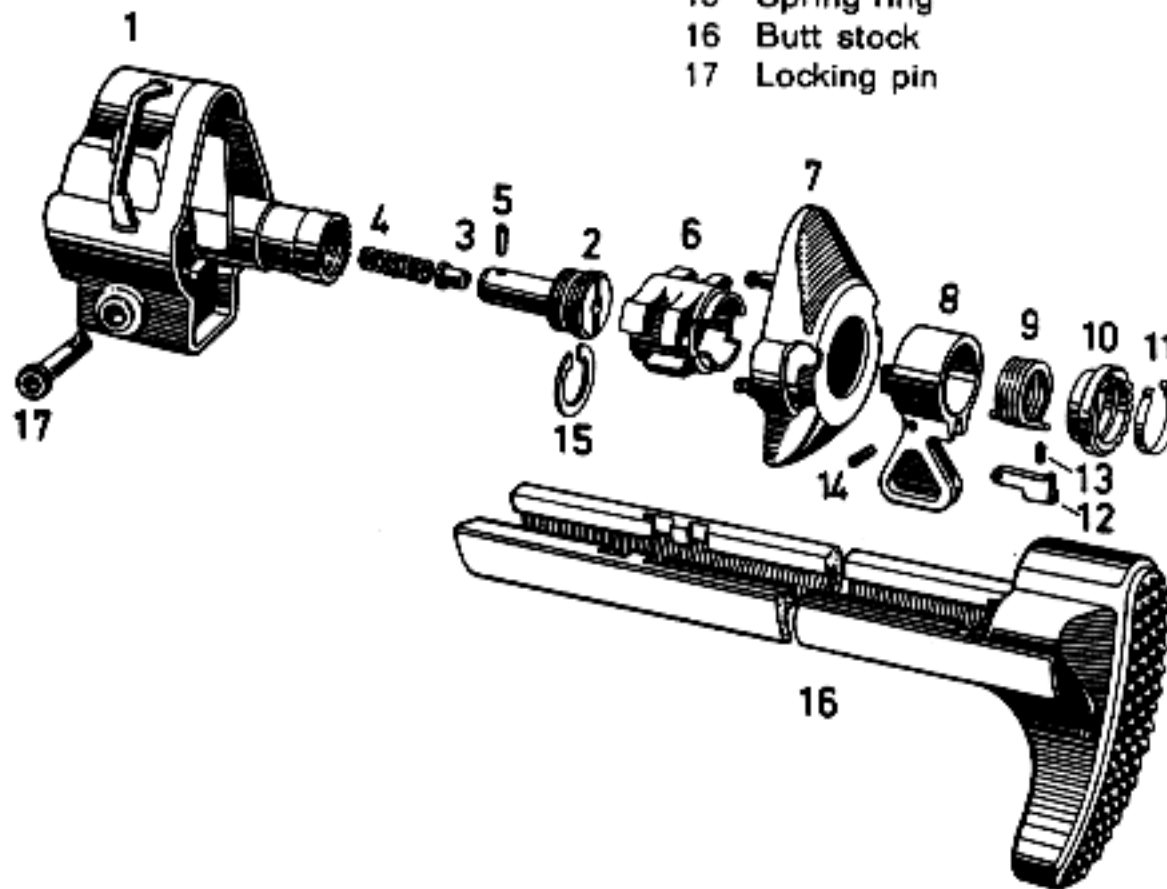

Fig. 25: Retractable butt stock

The „retractable butt stock“ is interchangeable with the „rigid butt stock“. Seated on the buffer housing of the back plate are the gripping lever (25/6), the tension lever (25/8) and the locking ring (25/10) with which the retractable butt stock is locked in its fully extended and fully retracted positions. They are held by the spring ring (25/15). The cover (25/7) closes the rear of the back plate (25/1).

The two guide rails slide on the buffer housing and fit into the guide grooves of the receiver when the butt stock is mounted.

Located within the buffer closure is a compression bolt (25/3) with compression spring (25/4). It presses the butt stock (25/16) rearwards after unlocking by means of tension lever.

1.5.1.5. Handguard

The plastic handguard (26/1) encircles the barrel from below. It makes the rifle easier to handle when the barrel is hot. A sheet metal lining is riveted to the inside as a thermal shield. A holder (26/2) has been riveted to the handguard for the hook-in of the combat carrying sling. The handguard is attached to the rifle with the locking pin (26/3).

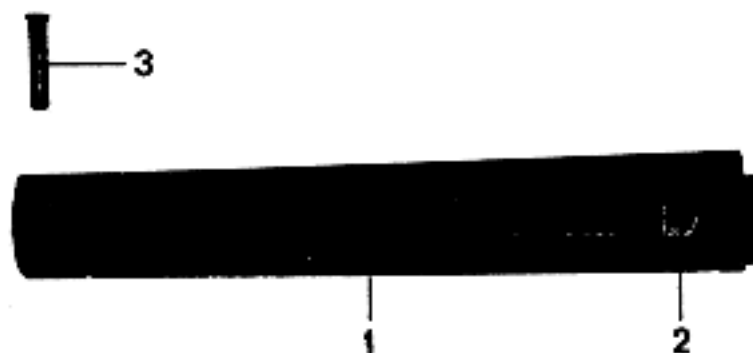

Fig. 26: Handguard

1.5.1.6. 20-Round Magazine

- 1 Magazine housing
- 2 Follower
- 3 Follower spring with safety plate
- 4 Floor plate

The magazine holds and feeds the cartridge. It is a 20-round magazine.

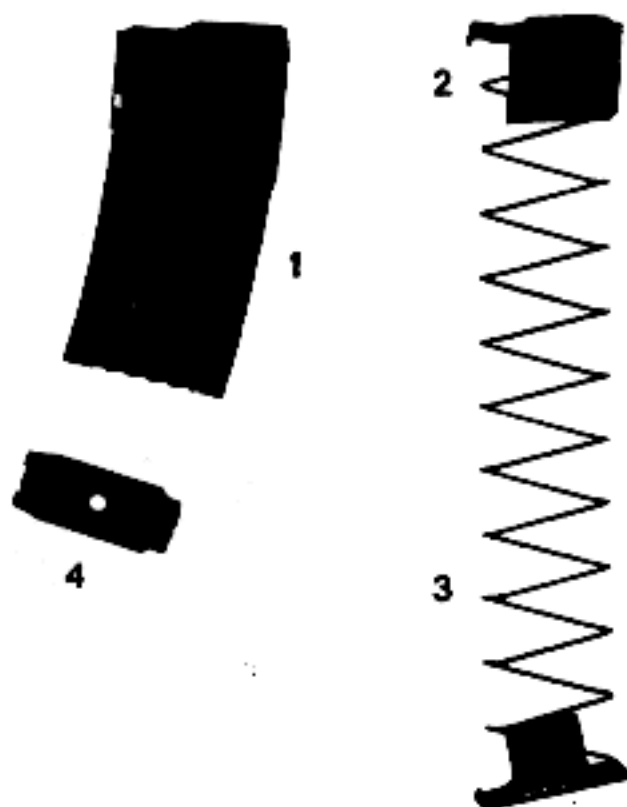

Fig. 27: 20-round magazine

Available in addition to the magazine (27) is a 40-round magazine (28).



Fig. 28: 40-round magazine

1.5.1.7. Scopes

1.5.1.7.1. Telescopic Sight with Mount

The telescopic sight is used for employing the Rifle HK33 as a sniper rifle. It enables the shooter to locate the target and aim by day or at dusk. The maximum distance which can be ranged is 600 metres. It can also be used for observing the enemy at greater distances.

The telescopic sight (29/1) is attached to the mount (29/2) by two screws (29/3). The HK33 receiver is so designed that the telescopic sight with mount can be placed on any rifle without modifications. The telescopic sight mount is marked the corresponding serial number of the rifle.

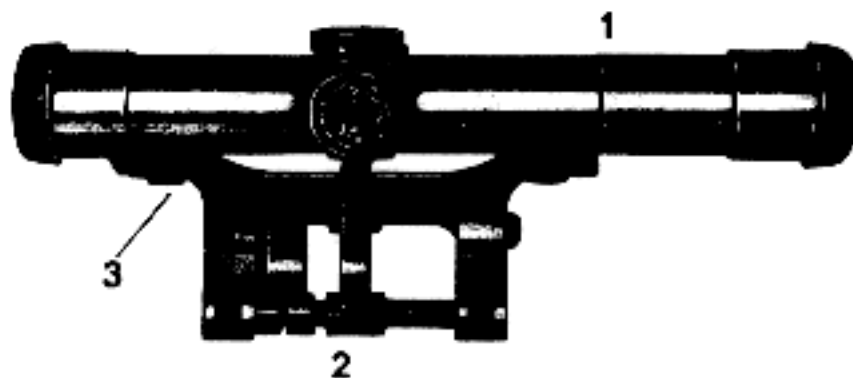

Fig. 29: Telescopic sight with mount

1.5.1.7.2. Infrared Scope with Mount

The infrared scope is designed for use with the Rifle HK33 for aiming and observing at night with the infrared spotlight.

In night operations, it enables the shooter to observe and aim by means of infrared illumination and the infrared spotlight.

The infrared scope (30/1) is attached to the telescopic sight mount (30/2) by means of two screws (30/3).

The HK33 receiver is so designed that the infrared scope with mount can be placed on any rifle without modifications. The telescopic sight mount is marked with the corresponding serial number of the rifle.

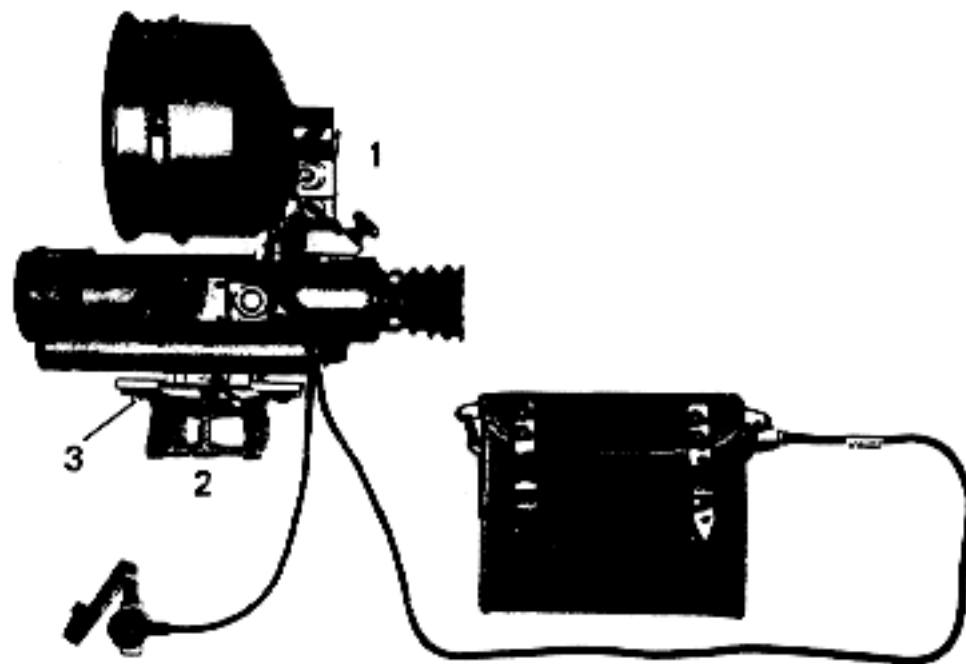

Fig. 30: Infrared scope with mount

1.5.1.8. Training Equipment

1.5.1.8.1. Blank Attachment

- | | | | |
|---|------------------|---|-------------|
| 1 | Blank attachment | 4 | Nozzle bolt |
| 2 | Retaining spring | 5 | Cup springs |
| 3 | Cylindrical pin | | |

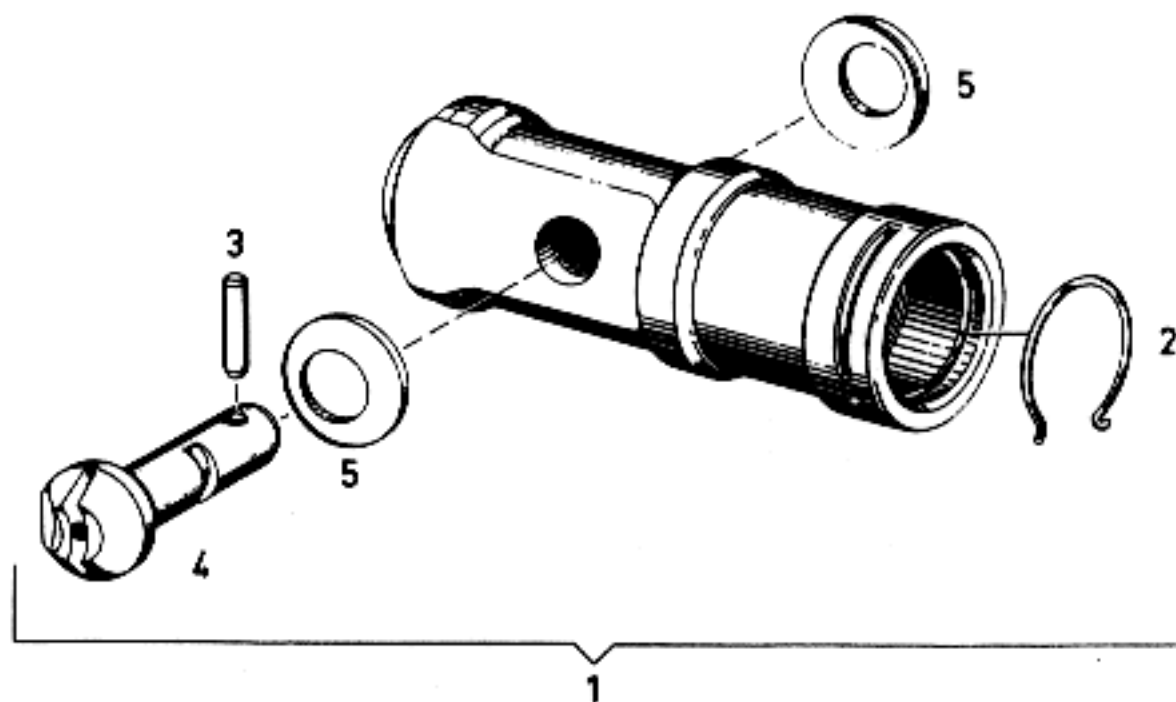

Fig. 31: Blank attachment

The blank attachment (31/1) is a training device for firing 5.56 mm x 45 blank ammunition. It is screwed onto the barrel in place of the flash suppressor. The retaining spring (31/2) in the rear engages in the longitudinal grooves of the barrel shoulder and secures the blank attachment against working loose.

Located in the front of the blank attachment are the nozzle bolt (31/4) and cup springs (31/5), held in place by the cylindrical pin (31/3). The gas pressure can be regulated by rotating the nozzle bolt.

The blank attachment must be threaded tightly to the barrel. To distinguish it from the flash suppressor, the blank attachment has a **dull chrome finish**.

1.5.1.8.2. **Subcalibre Conversion Kit for .22 LR (5.6 mm x 16) Ammunition**

- 1 Subcalibre tube .22 Cal. (5.6 mm)
- 2 Bolt assembly .22 Cal. (5.6 mm)
- 3 Magazine .22 Cal. (5.6 mm)
- 4 Container

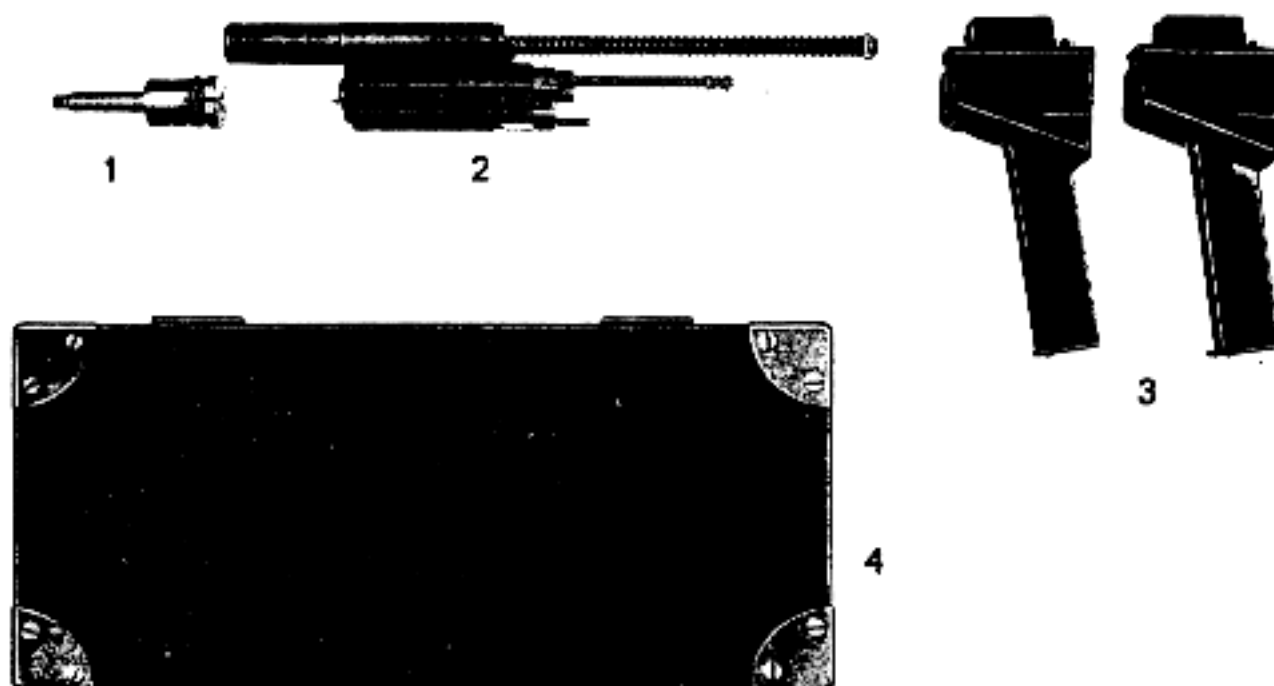

Fig. 32: Subcalibre conversion kit for .22 LR (5.6 mm x 16) ammunition

The subcalibre conversion kit is a training device for firing .22 LR (5.6 mm x 16) ammunition.

Subcalibre tube, .22 Cal. (5.6 mm)

- 1 Subcalibre tube .22 Cal.
- 2 Locking ring
- 3 Milled planes
- 4 Lateral slit

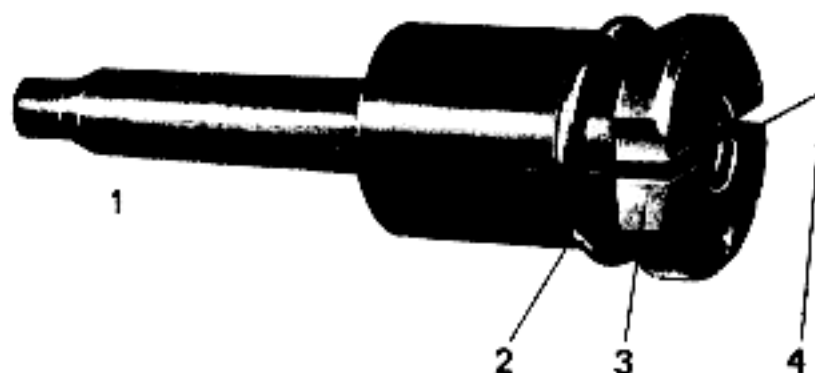

Fig. 33: Subcalibre conversion tube, .22 Cal. (5.6 mm)

The .22 Cal. (5.6 mm) subcalibre tube (33/1) is placed into the chamber of the Rifle HK33. The locking ring (33/2) prevents loosening from the barrel extension when the bolt is open and the magazine removed. The parallel milled planes (33/3) on the enlarged rear end of the tube fix it in the proper position within the barrel extension. The extractor fits in the lateral slit (33/4). The tube interior is divided into a chamber and a rifled section.

Bolt Assembly, .22 Cal. (5.6 mm)

The bolt head fits in the bolt head carrier and together with the cartridge case, seals the rear of the chamber when firing. It also feeds and fires the round, extracts and ejects the empty cartridge case and cocks the hammer.

- | | | | |
|---|--------------------------|---|---------------------------------------|
| 1 | Guide rod | 6 | Washer |
| 2 | Bolt head carrier | 7 | Buffer spring |
| 3 | Bolt head with extractor | 8 | Safety plate |
| 4 | Recoil spring | 9 | Recoil spring with recoil spring tube |
| 5 | Guide sleeve | | |

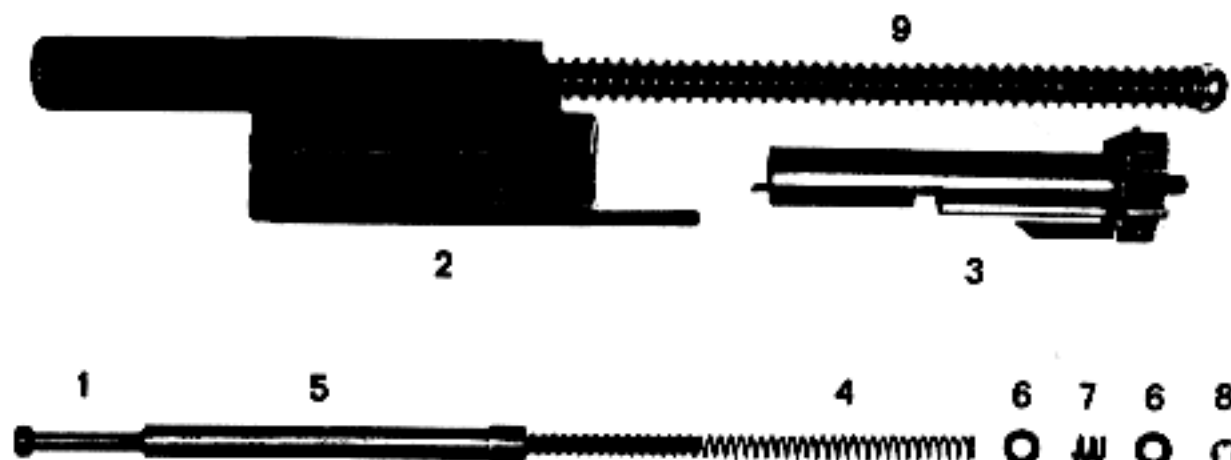

Fig. 34: Bolt assembly, .22 Cal. (5.6 mm)

Located in the bolt head carrier (34/2) is the bolt with extractor (34/3), which is connected to the guide sleeve (34/5). Located on the guide rod (34/1) are the recoil spring (34/4) with washer (34/6), buffer spring (34/7) and safety plate (34/8). The bolt head carrier and the bolt head move only when the rifle is being cocked; when firing, however, only the bolt head recoils.

- | | |
|---------------------|---------------|
| 1 Bolt head | 6 Spring |
| 2 Extractor | 7 Limit stop |
| 3 Shock absorber | 8 U-clip |
| 4 Firing pin | 9 Guide plate |
| 5 Firing pin spring | |

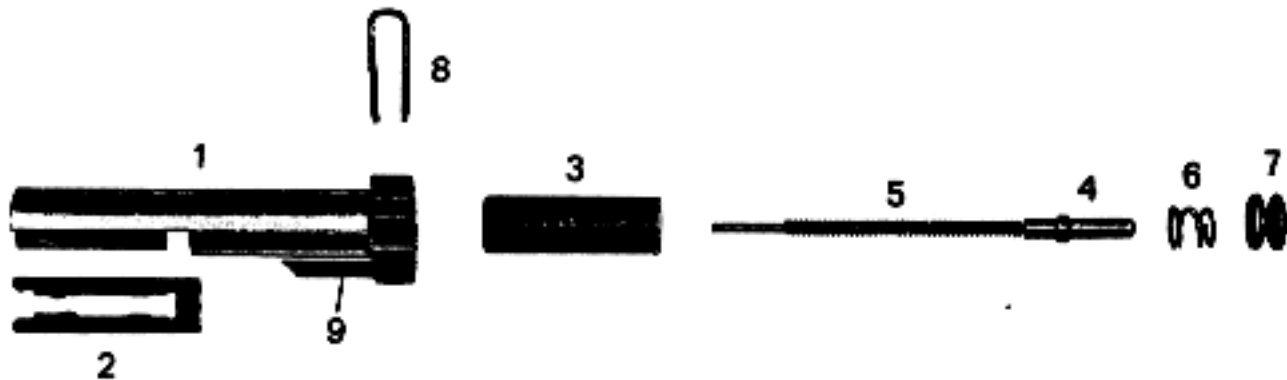

Fig. 35: Bolt head assembly

The bolt head (35/1) contains the extractor (35/2), the shock absorber (35/3) with spring (35/6) and the firing pin (35/4) with firing pin spring (35/5). The limit stop (35/7) with U-clip (35/8) forms the stop for the shock absorber and the firing pin. Located at the rear of the bolt head is the guide plate (35/9); the ramp at its base pushes the hemmer downward as the bolt recoils.

Magazine .22 Cal. (5.6 mm)

A magazine (36/2) for twenty .22 LR (5.6 mm x 16) cartridges is built into an insert (36/1). The built-in magazine holds and feeds the cartridges.

- | |
|-------------------------------------|
| 1 Insert |
| 2 Magazine .22 Cal. (5.6 mm) |
| 3 Magazine floor plate |
| 4 Follower |
| 5 Follower spring with safety plate |

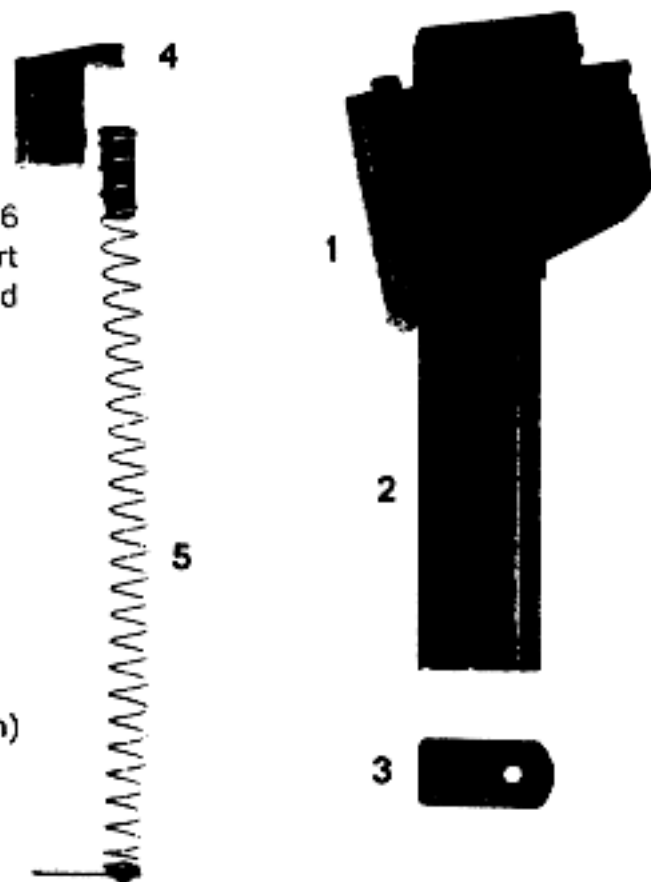

Fig. 36: Magazine .22 Cal. (5.6 mm)

Container

Stored in the container are the subcalibre tube (37/1), the bolt assembly (37/2) and two magazines (37/3).

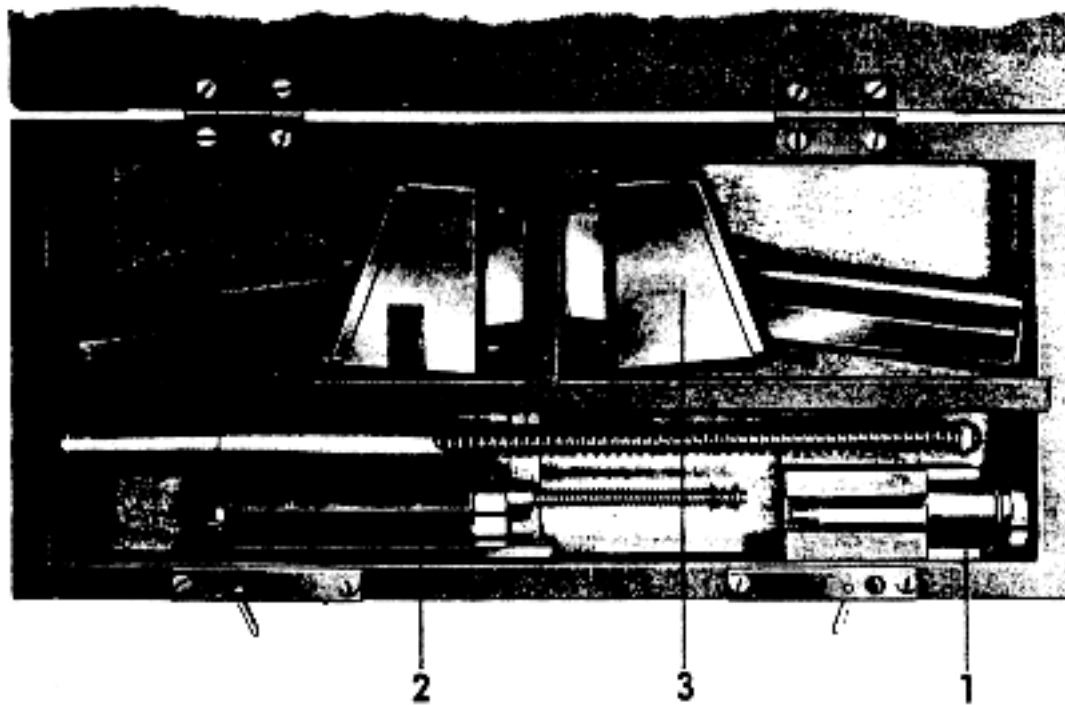

Fig. 37: Container

1.5.2. Operation

1.5.2.1. Bolt Assembly

The rifle is loaded and cocked and the safety is disengaged. Pulling the trigger releases the cocked hammer. It strikes the firing pin (38/4), which ignites the cartridge (38/1). The powder gases force the bullet out of the barrel (38/5), while simultaneously pressing against the cartridge case. The base of the cartridge case transmits a portion of the gas pressure to the bolt head (38/2) and from there via the locking rollers (38/7) and the locking piece (38/3) to the bolt head carrier, thus causing the bolt to unlock and recoil.

- | | |
|-----------------|---------------------|
| 1 Cartridge | 5 Barrel |
| 2 Bolt head | 6 Barrel extension |
| 3 Locking piece | 7 Locking roller |
| 4 Firing pin | 8 Bolt head carrier |

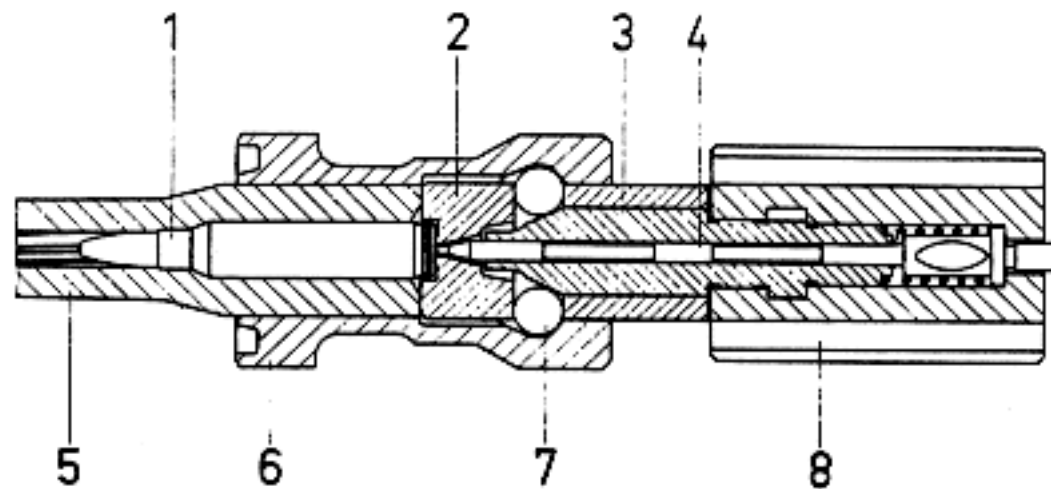

Fig. 38: Bolt locked

On the basis of the geometric relationship arising from the angles of the roller contact surfaces of the locking piece and the barrel extension, the recoil of the bolt head is delayed in the ratio of 1 :3. Thus, during the same period of time, the bolt head carrier travels 3 times as far as the bolt head; this ratio continues until the locking rollers have left the barrel extension (39).

Through the incorporation of this element, - the locking rollers - the weight of the bolt is reduced to approximately 1/9 of the weight of a pure inertia bolt.

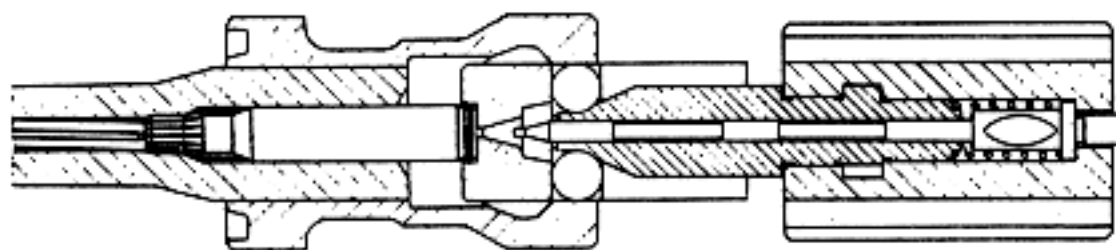

Fig. 39: Bolt unlocked

As the bolt head carrier travels backward, the bolt head locking lever (40/1) is simultaneously pressed over the bolt head shoulder against the pressure of its spring.

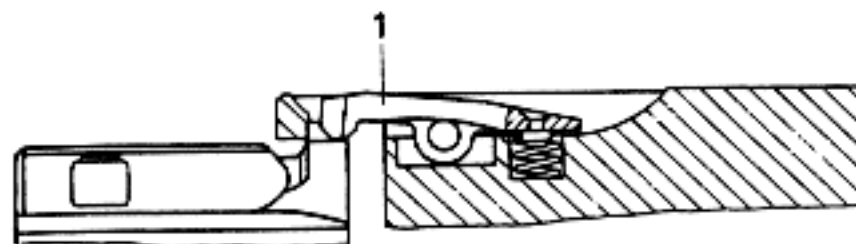

Fig. 40: Disengagement of the bolt head locking lever

After the round has been chambered, the bolt head stops at the mouth of the barrel. The bolt head carrier continues forward until the locking piece presses the locking rollers into engagement in the barrel extension. The bolt head locking lever now engages the bolt head shoulder thus preventing it from rebounding. As the bolt recoils, the hammer is cocked, and the recoil spring compressed, at the same time, the cartridge case held by the extractor strikes the ejector and is ejected. At the rear, the bolt strikes the buffer and is snapped forward again.

1.5.2.2. Bolt Assembly for .22 LR (5.6 mm) Ammunition

As opposed to the standard bolt in the Rifle HK33, the .22 Cal. (5.6 mm) bolt is a pure mass bolt. In this system, the barrel is sealed merely by means of the relatively great inertia of the bolt mass.

However, only the bolt head acts as a mass. It moves within the bolt head carrier and has its own recoil spring.

Only when the operating lever is retracted does the bolt head carrier move jointly with the bolt head.

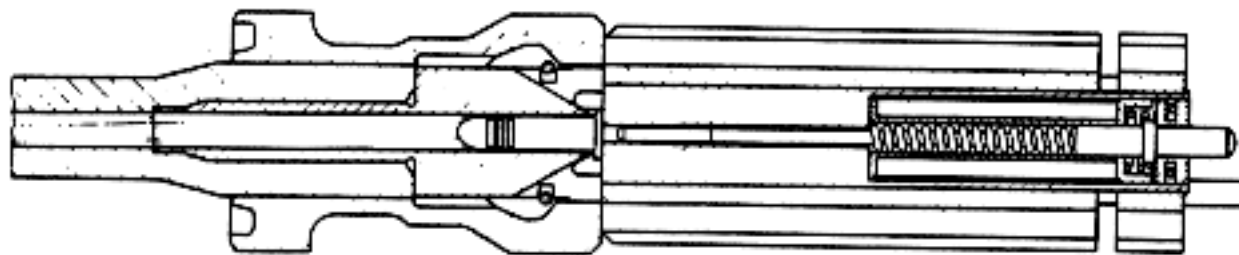

Fig. 41: Bolt closed

1.5.2.3. Trigger Mechanism

1.5.2.3.1. Initial Position at "S" = Safe

- | | |
|---------------------|---------------------------------------|
| 1 Bolt head carrier | 8 Forked bolt with compression spring |
| 2 Firing pin | 9 Catch with roller |
| 3 Release lever | 10 Elbow spring with roller |
| 4 Anvil for hammer | 11 Sear |
| 5 Trigger spring | 12 Trigger |
| 6 Hammer | |
| 7 Safety pin | |

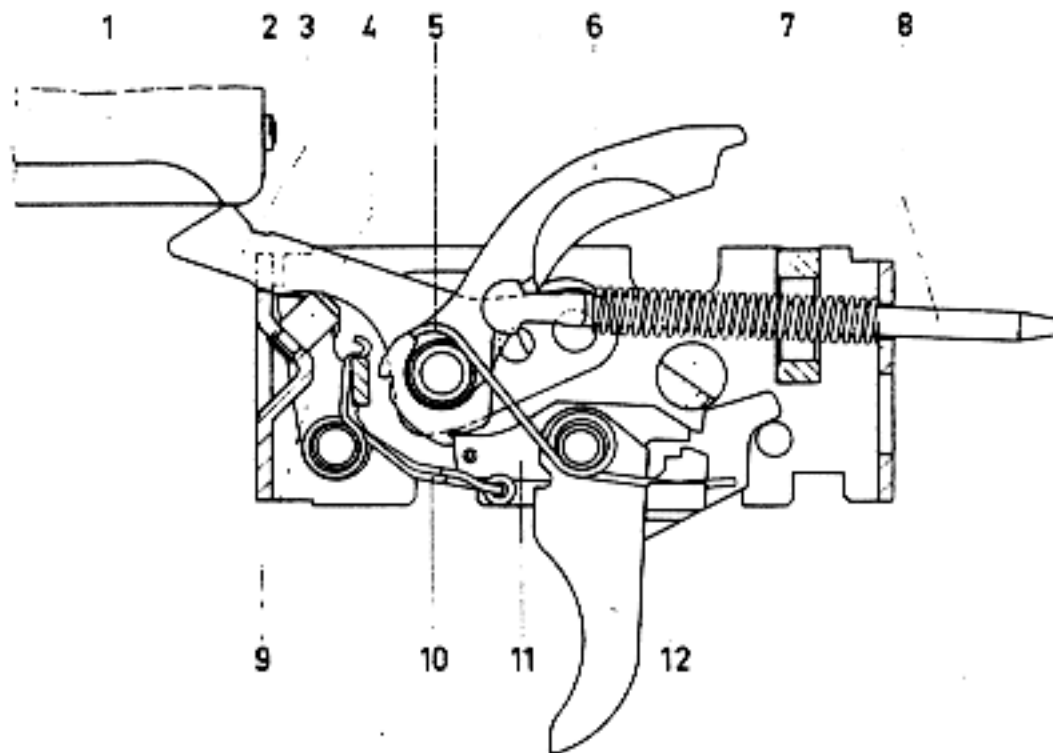

Fig. 42: Safety at "S" = Safe

The rifle is loaded and the hammer (42/6) cocked. The safety (42/7) is at "S" = Safe.

As the bolt travels forward, the bolt head carrier (42/1) presses against the release lever (42/3). This causes the catch (42/9) to swivel forward and disengage the hammer's „burst" notch.

The hammer (42/6) now rests against the sear (42/11) with its „single fire“ notch. Against the pressure of the compression bolt and spring (43/2) the sear is forced to move back approx. 1.5 mm and to come to rest over the trigger lever (43/3).

- 1 Slot
- 2 Compression bolt with spring
- 3 Trigger lever
- 4 Pull-off surface
- 5 Elbow spring with roller

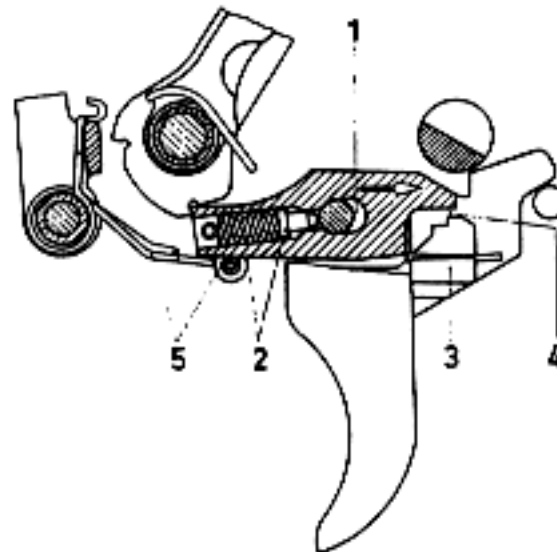

Fig. 43: Sear

A slot (43/1) in the sear permits this longitudinal shift. In this position, the trigger (42/12) is blocked by the safety pin and cannot be pulled.

1.5.2.3.2. Function in Position "E" = Single Fire

The selective fire lever is set at "E" = single fire. The safety pin permits a limited trigger pull.

- 1 Cam surface
- 2 Notch for burst
- 3 Notch for single fire
- 4 Notch for sear
- 5 Recess for single fire

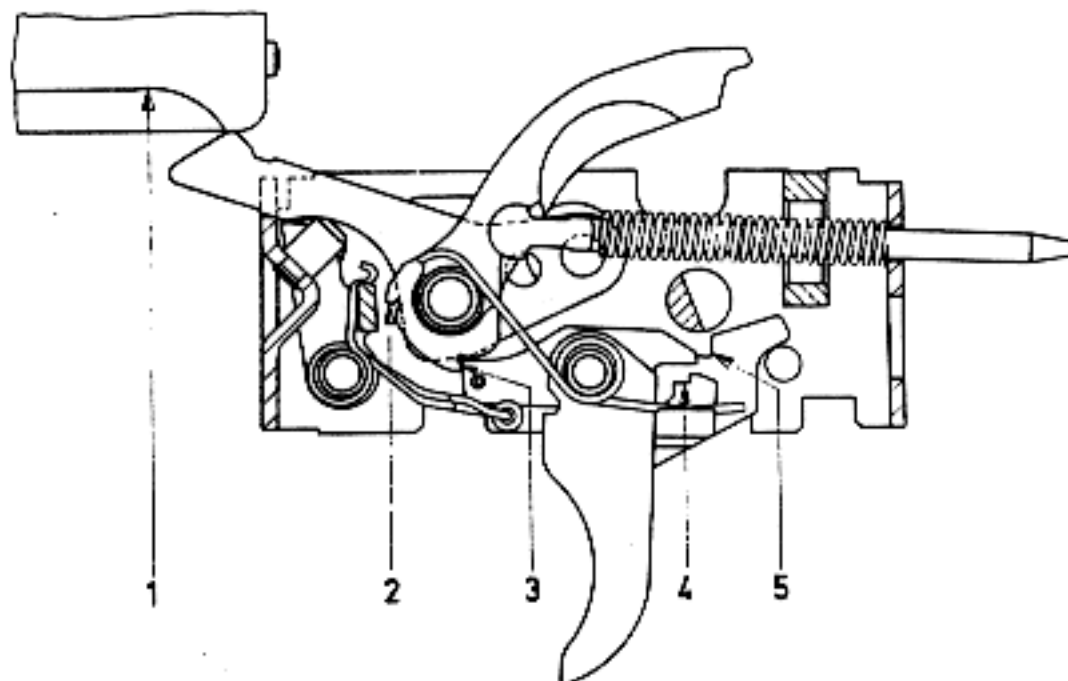

Fig. 44: Selective fire lever at "E" = single fire

As the trigger is pulled, the „pull-off point” position is reached, i. e. the trigger lever contacts the sear.

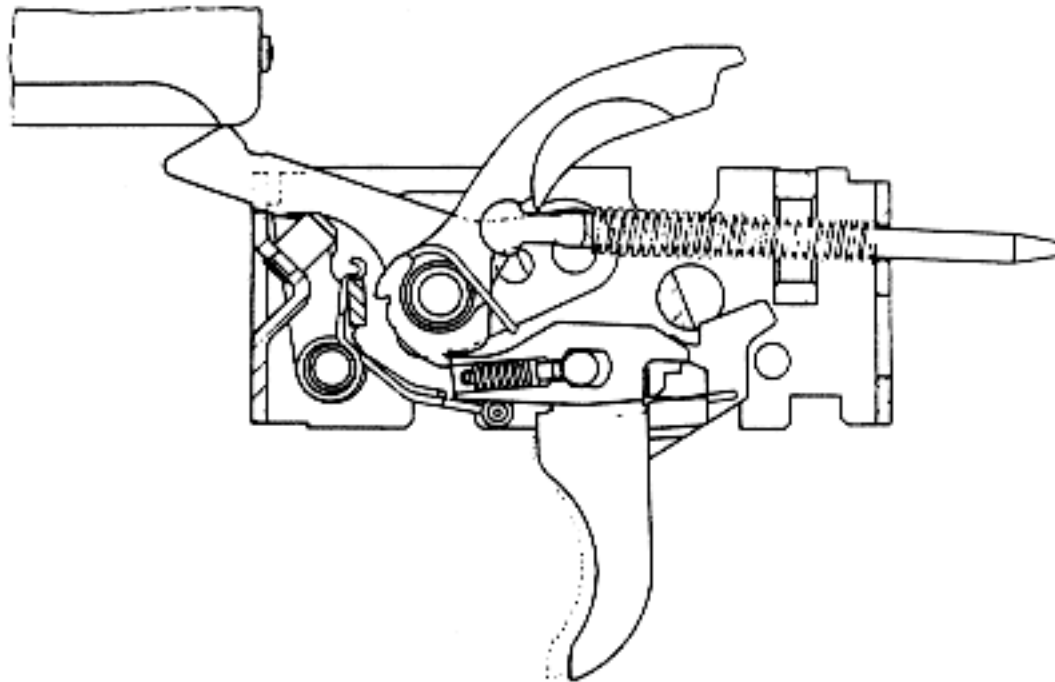

Fig. 45: Single fire function - pull-off point -

As the trigger is pulled further, the sear is pulled out of the „single fire” notch and releases the hammer.

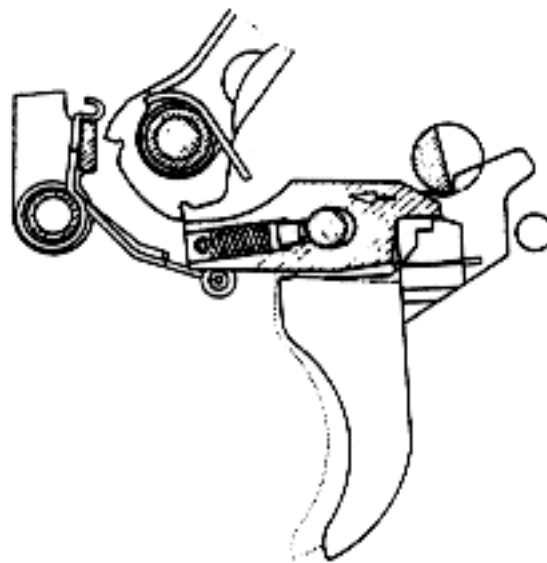

Fig. 46: Hammer release

The cartridge is ignited. At this moment the sear is released from the cocked hammer and, under the pressure of the compression bolt with spring (43/2), moves forward. The catch spring with roller swivels the front of the sear upward; the rear of the sear engages the notch for the sear.

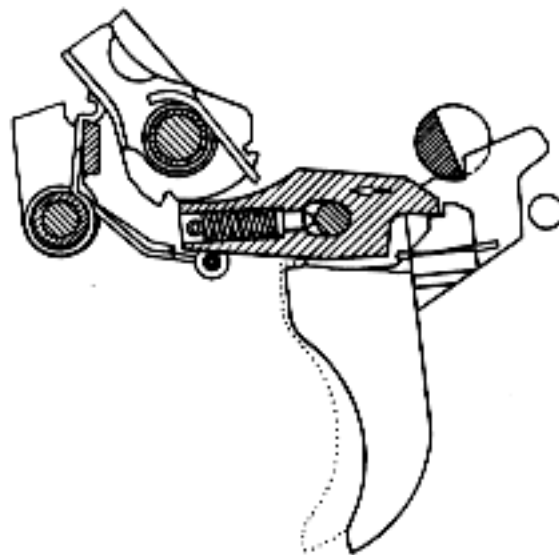

Fig. 47: After firing

As the bolt recoils, it pushes the hammer backward against the pressure of its spring, causing the sear to engage the „single fire“ notch.

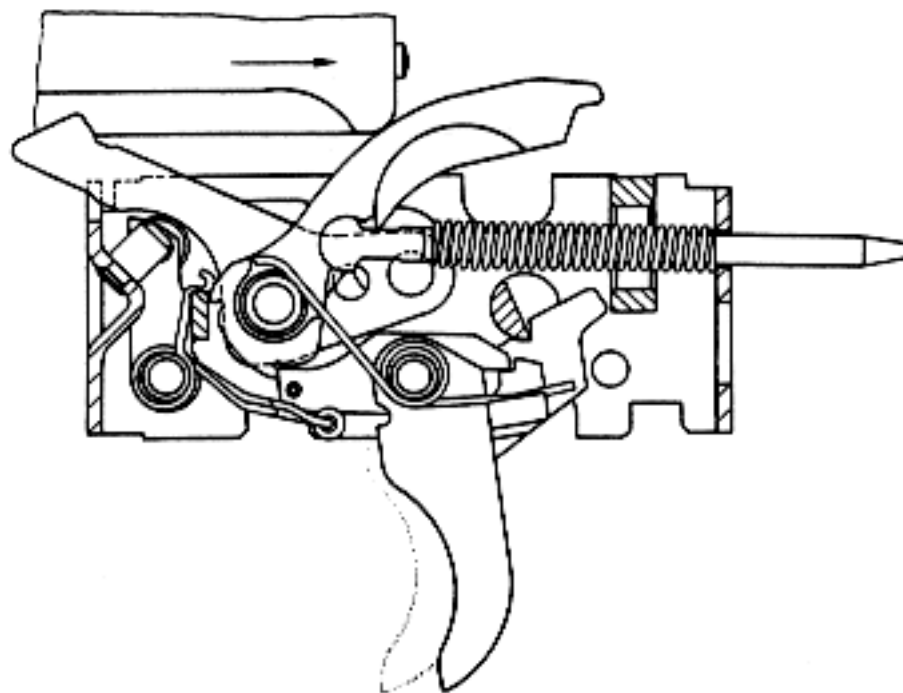

Fig. 48: Bolt recoil

Immediately thereafter, the catch engages the „burst“ notch.

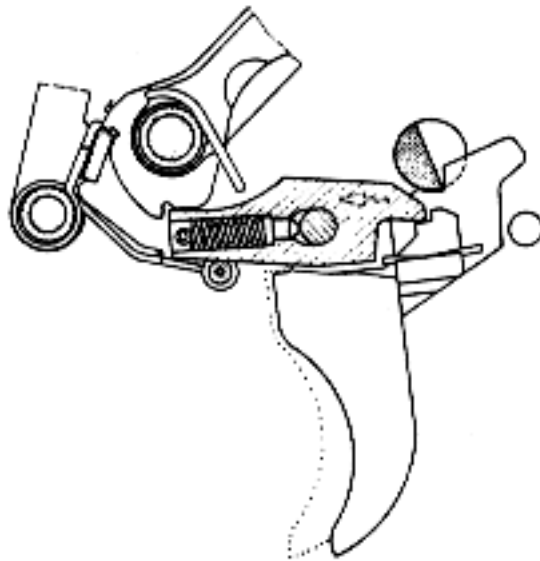

Fig. 49: Catch engaging the „burst“ notch

After the bolt has returned to its forward position, it presses the release lever downward and releases the catch. The hammer is now held only by the sear. However, it is not possible for the sear to move as it continues to be engaged in the „single fire“ notch in the hammer and in the notch in the trigger lever as long as the trigger has not been released.

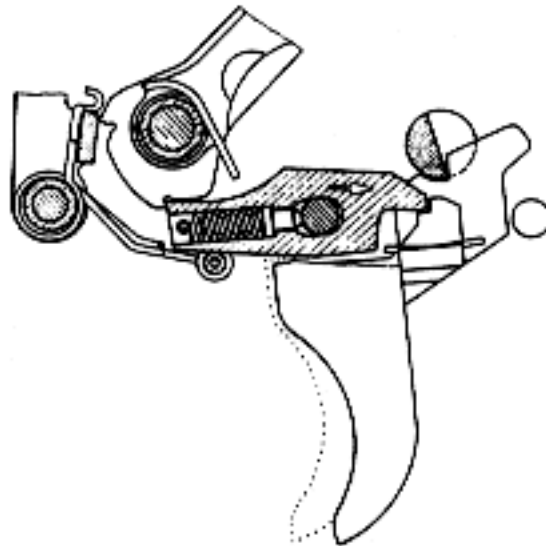

Fig. 50: After firing

In order to fire the next shot, the trigger must be released. This causes the hammer to push the sear back approx. 1.5 mm, placing it above the trigger lever. The next shot can now be fired.

1.5.2.3.3. Function in Position "F" = Burst

Setting the selective fire lever at "F" = burst results in a longer trigger travel, which is required only for automatic fire.

When the trigger is pulled, the first shot is fired in the same manner as if the selective fire lever were at "E" = single fire. However, the longer trigger travel swivels the sear so far downward that it can no longer catch the hammer. The hammer is now held only by the catch.

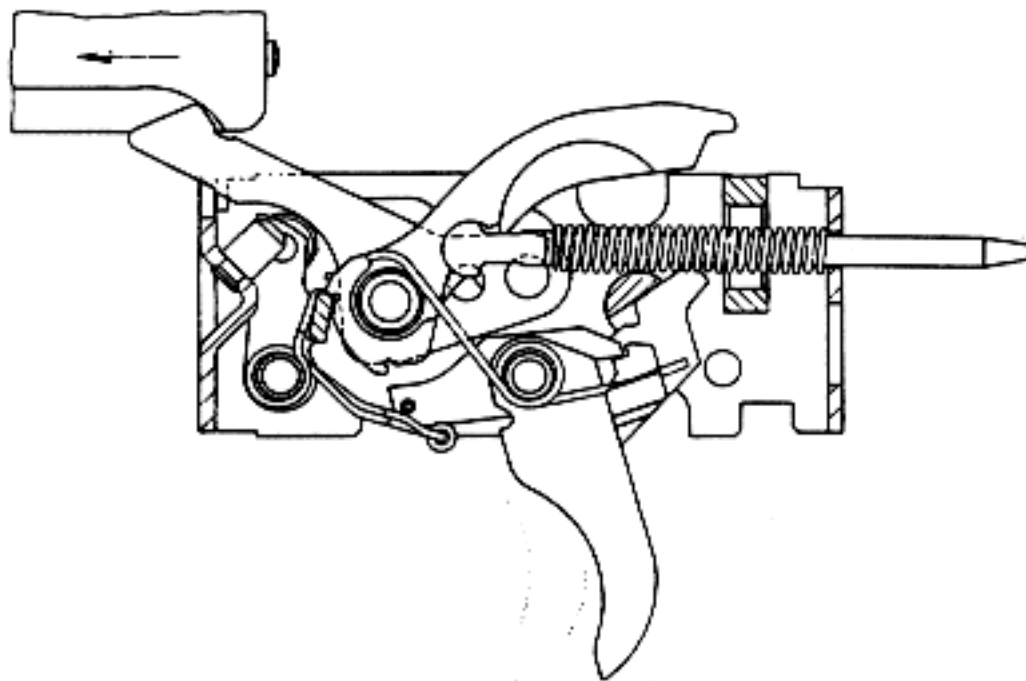

Fig. 51: Burst function

As the bolt snaps forward, it pushes the release lever downward, disengages the catch and releases the hammer.

As this function repeats, it results in automatic (burst) fire.

When the trigger is released, the front of the sear swivels upward again and engages the „single fire“ notch in the hammer.

NOTE

In the single fire position:

The firing sequence is interrupted by means of the sear in conjunction with:

- the position of the safety pin;
- the slot in the sear;
- the trigger spring with roller;
- the „single fire“ notch
- the notch for the sear.

In the burst position:

There is no interruption in the burst position:

- due to the position of the safety pin, producing a longer trigger travel;
- due to the sear, which swivels so far downward that it no longer contacts the „single fire“ notch;
- due to the catch which, through the release lever, releases the hammer as soon as the bolt is fully forward and locked.

1.6. Equipment

1.6.1. Accessories

- | | | | |
|---|---------------------------------------|---|-------------------|
| 1 | Combat carrying sling | 5 | 40-round magazine |
| 2 | Muzzle cover | 6 | Bipod |
| 3 | Cleaning kit for cal. 5.6 mm - 6.5 mm | 7 | Bayonet holder |
| 4 | 20-round magazine | | |

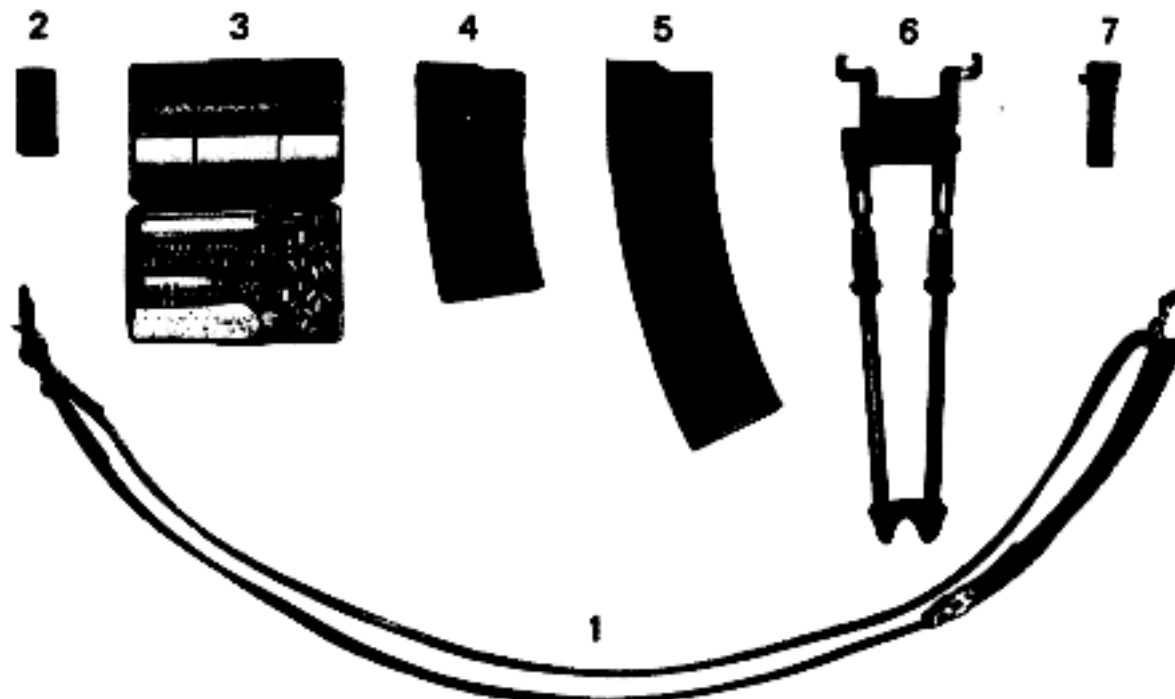

Fig. 52: Accessories

2.1. Instructions for Use

2.1.1. Principles of Handling and Use

1. Always handle the Rifle HK33 as if it were loaded and ready to fire.
2. The selective fire lever must always be set at "S" = safe. Switch to "E" = single fire or "F" = burst only when you are ready to fire.
3. When cocking, engaging the safety, loading, disengaging the safety or unloading the weapon, always point the muzzle upward and away from you.
4. 5.56 mm x 45 blank ammunition and 5.6 mm x 16 ammunition may only be used with the corresponding training equipment (cf. Section 1.5.1.8.).

2.1.2. Preparing the Rifle for Firing

Before loading and firing:

1. Free bore of oil.
2. Check operation of bolt and safety mechanisms.
3. Magazine must engage properly.
4. Check seat of flash suppressor or blank attachment.

2.1.2.1. Cocking

Before loading:

- Set selective fire lever at "S" = safe.
- Pull back operating lever and engage in the recess in the cocking lever housing.
- Push filled magazine into the magazine well until it engages.
- Permit cocking lever to snap forward.

The rifle is loaded with the safety engaged.



Fig. 53: Insert magazine

2.1.2.2. Firing

- Disengage the safety and select the desired firing mode.
 - Pull the trigger.
- Engage the safety whenever firing is interrupted or completed.

2.1.2.3. Uncocking

- Check to make sure that the fire selector lever is at "S" = safe.
- Remove magazine by pushing magazine catch lever forward.
- Pull back cocking lever and check to make sure that the chamber is empty.
- Permit cocking lever to snap forward again.
- Disengage the safety and pull the trigger.
- Engage the safety.



Fig. 54: Remove magazine

2.1.2.4. Filling and Emptying the Magazine

- To fill, press the cartridges into the magazine individually.
- To empty, grasp the magazine with one hand so that the tips of the cartridges point downward.
- Using a suitable piece of wood, press the second cartridge downward; the top cartridge will fall out by itself.



Fig. 55: Empty magazine

2.1.2.5. Launching Rifle Grenades

- Engage the safety.
 - Remove magazine.
 - Pull back cocking lever and engage in the recess in the cocking lever housing.
 - Insert propellant charge into the chamber by hand.
 - Permit the cocking lever and the bolt to snap forward.
 - Push rifle grenade over the flash suppressor as far as it will go. Make sure that the spring ring retains the grenade.
- As soon as the safety is disengaged the rifle is ready to launch the grenade.



Fig. 56: Insert propellant charge



Fig. 57: Rifle grenade mounted and ready to launch

2.1.2.6. Firing with Training Equipment

2.1.2.6.1. Blank Attachment

- Engage the safety.
- Unscrew flash suppressor
- Screw on blank attachment and tighten manually.
- Fill magazine with blanks and insert magazine in rifle.
- Chamber the first round by pulling back and releasing the cocking lever.
- Disengage the safety and select desired mode of fire.
- Pull trigger.

Engage the safety whenever firing is interrupted or completed.

Remove the magazine when regulating the gas outlet.

- Rotate the nozzle bolt with the aid of a cartridge base.
- „Minimum” gas outlet: „screw slot at right angles to the direction of fire”.
- „Maximum” gas outlet: „screw slot in line with the direction of fire”.



Fig. 58: Blank attachment mounted

2.1.2.6.2. Subcalibre Conversion Kit for .22 LR (5.6 mm x 16) Ammunition

- Engage the safety.
- Remove magazine and bolt assembly.
- Insert subcalibre tube in the chamber of the Rifle HK33.
Check proper seat of the subcalibre tube by inserting the .22 Cal. (5.6 mm) magazine.
- Insert .22 Cal. (5.6 mm) bolt assembly in the receiver.
- Check the proper assembly of the rifle by pulling back and releasing the operating lever several times.
- Fill .22 Cal. (5.6 mm) magazine with cartridges and insert in rifle.
- Cock the rifle by pulling back and releasing the operating lever.
- Disengage the safety and select desired mode of fire.
- Pull trigger.

Engage the safety whenever firing is interrupted or completed.

2.1.3. Using the Rifle with Scopes

2.1.3.1. Telescopic Sight with Mount

To use the Rifle HK33 as sniper rifle, the telescopic sight is mounted as follows:

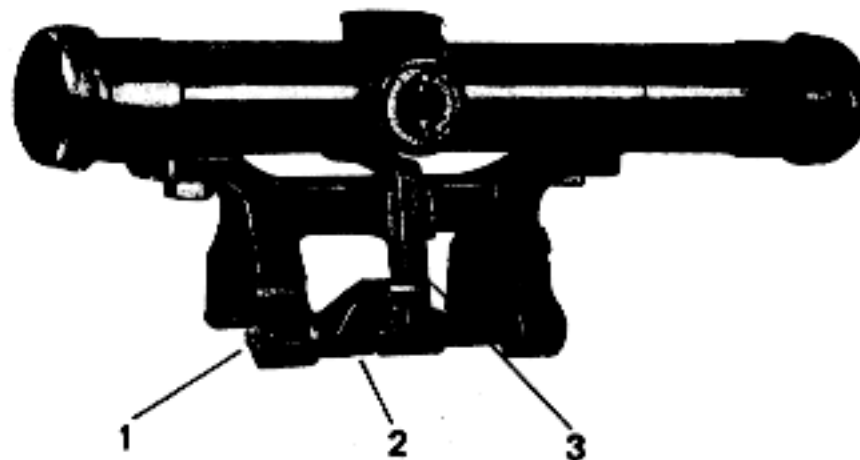

Fig. 59: Telescopic sight with mount

- Before mounting, swivel the claws (59/1) on the mount outward.
- Place mount on the rifle from above, keeping the mount tilted slightly to the right and rest its plastic nose against the sight cylinder.
Note the inscription „direction of fire” and „arrow” on the bottom of the mount.

- Press tension lever (59/2) downward until the catch (59/3) is heard to engage.
- Raise tension lever as far as it will go.



Fig. 60: Mounting the telescopic sight with mount

Removing the Telescopic Sight

- To remove the telescopic sight with mount, push tension lever downward.
- Press catch downward with thumb and raise tension lever again.
- Tip telescopic sight with mount to the right and remove.

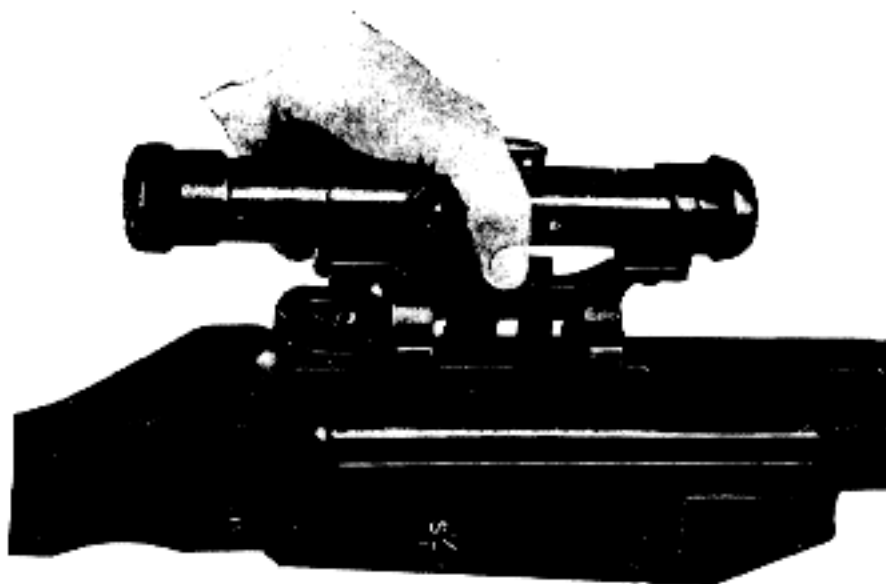

Fig. 61: Removing the telescopic sight with mount

Before placing in the carrying bag, swivel claws inward.

2.1.3.2. Infrared Scope with Mount

To use the Rifle HK33 with the infrared scope, the telescopic mount must be placed on the receiver.

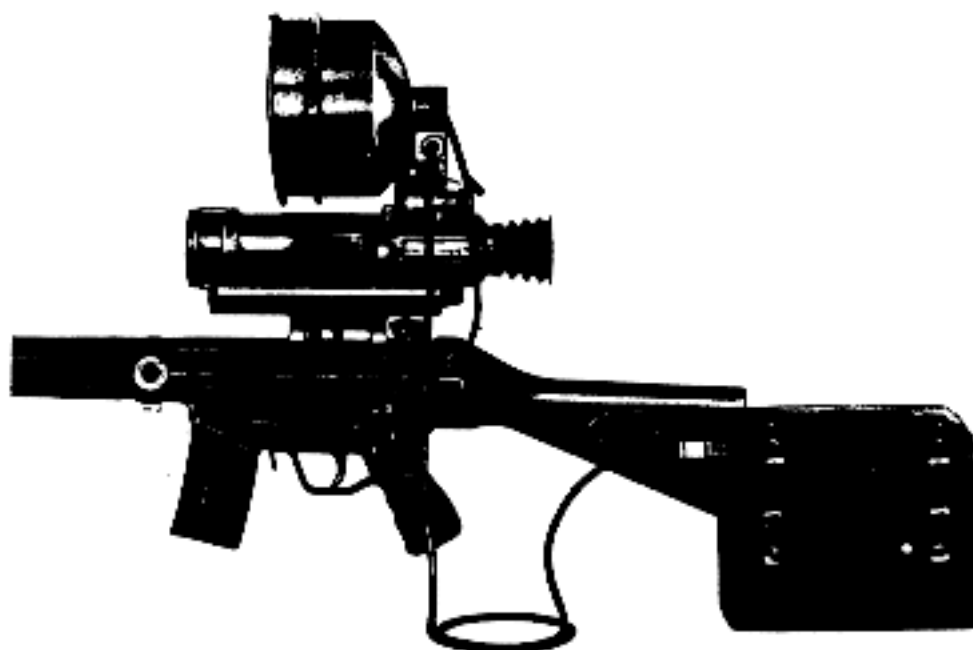

Fig. 62: Infrared scope mounted with telescopic sight mount

The infrared scope with mount is **mounted** in the same manner as the telescopic sight with mount. In addition, the push button switch must also be mounted to the rifle with its holding device.

The infrared scope with mount is **removed** in the same manner as the telescopic sight with mount.

2.1.4. Using the Rifle under Extreme Climatic Conditions

No special procedures are required for using the rifle under damp, extremely hot or extremely cold (to approx. - 40° C.) conditions.

Avoid bringing rifles, training equipment or scopes from cold to warm locations and then immediately returning them to cold locations as the weapon may not function properly due to moisture, sweating, ice or rust.

2.2. Maintenance

2.2.1. General

Proper handling and maintenance of the rifle and equipment

- ensures readiness to fire,
- reduces premature wear,
- prevents accidents,
- saves repair costs and time.

The user (bearer of the weapon)

- is responsible for
 - cleaning,
 - maintenance,
 - general condition,
 - completeness (including accessories) of the rifle issued to him,
 - must report damages and malfunctions immediately.

The major cleaning must be performed

- after every firing,
- if the rifle has become wet, or
- when the rifle is dusty.

The normal cleaning must be performed

- at regular intervals if the rifle has not been used,

The Rifle HK33 must be checked for damage, smooth and proper function every time it is cleaned or assembled.

2.2.2. Stripping and Assembling the Rifle and the Training Equipment for Cleaning

Note

The user is not permitted to strip the Rifle HK33, its assembly groups or training equipment beyond the limits indicated in Section 2.2.2.

The rifle and the training equipment can be stripped for cleaning without any tools.

Stripping the Rifle

Engage the safety!

- Remove magazine,
- Unload rifle,
- Check if barrel is clear,
- Unsnap sling at front eyebolt,
- Press out both locking pins in the back plate and insert them in the tubular rivets in the butt stock,

— Remove back plate with butt stock.



Fig. 63: Remove rigid butt stock

- Swing down grip assembly,
- Press out grip assembly locking pin and remove grip assembly,
- Pull back bolt assembly with the cocking lever and remove.
- Push cocking lever forward again.



Fig. 64: Remove bolt assembly

- Unscrew flash suppressor or blank attachment.
- Press out handguard locking pin and remove handguard.

Stripping the Bolt Assembly. The bolt assembly should only be stripped for a major cleaning.

To strip the bolt assembly grasp the bolt head carrier with one hand, rotate the bolt head with the other hand and pull it from the locking piece.



Fig. 65: Strip bolt assembly

Rotate locking piece slightly. This will free the firing pin and firing pin spring, which can then be removed together from the bolt head carrier.



Fig. 66: Remove locking piece with firing pin spring

The bolt is assembled in reverse sequence. Care should be taken with the following:

Push locking piece with its stud into the recess in the bolt head carrier as far as it will go and rotate approx. 90° towards the check lever until the stud is visible in the opening at the bottom of the bolt head carrier.

Push bolt head onto the locking piece in such a manner that the tapered surface of the bolt head stops in front of the nose of the check lever.

Push bolt head against the pressure of the check lever spring as far as it will go. Pull the bolt head forward approx. 5mm (1/4") in this position.

Rotate the bolt head until its base is even with the base of the bolt head carrier. Press recoil spring into recoil spring tube.

Stripping the Grip Assembly (Only required for major cleaning):

- Release hammer,
- Rotate selective fire lever until it points upward and extract,
- Remove trigger assembly housing from grip assembly.

The grip is assembled in reverse sequence. After assembling, set selective fire lever at "S" = safe.

Assembling the Rifle

The rifle is assembled in reverse sequence.

- Insert the assembled bolt into the receiver. The locking rollers must be located in the bolt head. (See assembly of the bolt.)
- When swivelling up the grip assembly, make sure that the hammer is cocked.



Fig. 67: Assemble rifle

Check the proper assembly of the rifle by pulling back and releasing the cocking lever several times.

Stripping and Assembling the Magazine

Using a suitable piece of wood or a dummy cartridge, push in safety pin on the magazine floor plate and slide it off.



Fig. 68: Remove magazine floor plate

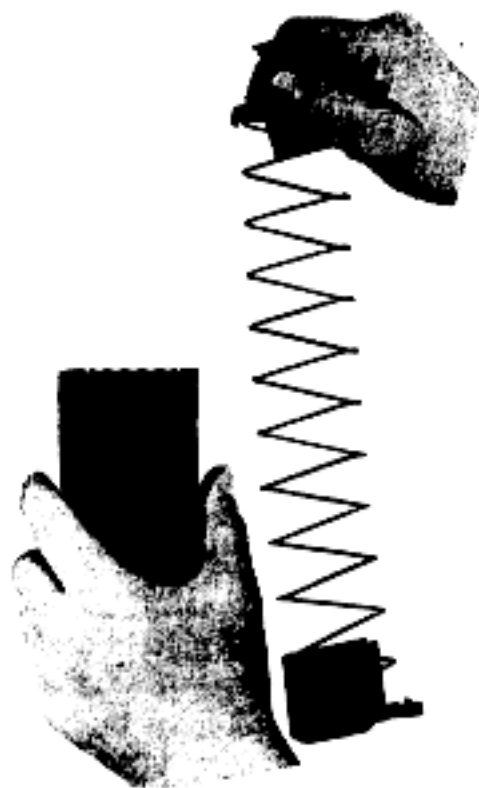

Fig. 69: Assemble magazine

Remove follower and follower spring with safety plate.
The magazine is assembled in reverse sequence.

Blank Attachment

It is not necessary for the user to strip the blank attachment.

.22 Cal. (5.6 mm) Subcalibre Bolt Assembly

- Remove locking disc from the guide rod,
- Remove bolt head with guide sleeve and recoil spring from the bolt head carrier from the rear,
- Remove guide rod from the bolt head carrier from the front.
- Using the base of a dummy cartridge, extract the U-clip on the bolt head; remove shock absorber, firing pin, firing pin spring, compression spring and limit stop.
- Remove extractor.



Fig. 70: Remove bolt head



Fig. 71: Strip bolt head

The bolt is assembled in reverse sequence.

Stripping and Assembling the .22 Cal. (5.6 mm) Magazine

- Push in the safety pin on the .22 Cal. (5.6 mm) magazine cover, slide magazine cover to the right and remove.
 - Remove follower and follower spring with safety plate.
- The .22 Cal. (5.6 mm) magazine is assembled in reverse sequence.



Fig. 72: Remove magazine cover

2.2.3. Maintenance Plan

No.	Location	Work	Interval			
			after use	before firing	after firing	weekly
1	Barrel	Clean and oil	x		x +)	x
	Barrel	Free of oil		x		
2	Flash suppressor	Clean and oil	x		x	x
	Flash suppressor	Check seat		x		x
3	Rear sight	Clean and check		x		
	Rear sight	Clean and oil	x		x	x
4	Bolt assembly	Clean and oil	x		x	x
	Bolt assembly	Strip, clean and oil				x
5	Recoil spring guide tube w. recoil spring	Clean and oil	x		x	x
	Butt stock	Clean	x		x	x
6	Butt stock, retractable	Clean and oil	x		x	x
	Grip assembly with trigger housing	Clean and oil	x		x	x
7	Handguard	Check seat	x	x	x	x
8	Magazine	Check for damage	x	x	x	x
	Magazine	Clean and oil Strip, clean and oil	x		x	x
10	Blank attachment	Clean and oil			x	x
	Subcalibre conversion kit for 5.6 mm x 16 ammo	Clean and oil			x	x
11	Accessories	Clean, check	x		x	x

+) Clean and oil for three days in a row after firing.

2.2.4. Special Notes Regarding Maintenance Products and Equipment

The following are to be used for cleaning and maintenance:

- the cleaning kit for cal. 5.6 mm to 6.5 mm
- clean patches and cleaning rags
- multi-purpose anticorrosive agent.

The rifle may not be cleaned

- with metallic objects
- with synthetics (e. g. Nylon, etc.)
- with chemical agents (e. g. gasoline, trichlorethylene, etc.)
- with hot or cold water.

2.2.5. Maintenance Instructions

2.2.5.1. Major Cleaning

- Strip, Section 2.2.2.
- Clean and dry using cleaning rags.
- Remove dirt and dust from joints and corners using the cleaning brush.
- Pull an oil-soaked cleaning brush through the barrel (best done while the barrel is still lukewarm, but not hot).
- Allow oil to work in for several hours.
- Then pull oil-soaked brush through the barrel several times again.
- Finally, use clean, dry patches until the barrel is clean.
- Oil barrel and moving parts lightly again.
- Assemble rifle.

Note

The barrel must be cleaned and oiled for three days in a row after firing.

2.2.5.2. Normal Cleaning

The normal cleaning is basically the same as the major cleaning.

However, the repeated cleaning and oiling of the barrel is not necessary.

2.2.6. Functional Test

2.2.6.1. Magazine

- The follower must be able to be pushed downward freely within the magazine housing by hand and the follower spring must be able to push it upward again without interference.
- The magazine must not jam in the magazine well.
- The magazine must be held securely by the magazine catch.

2.2.6.2. Operating Procedure

Engage the safety!

- Pull back operating lever and engage in the recess in the operating lever housing.
- Check if bore is clear.
- Insert magazine filled with two dummies into the rifle's magazine well.
- Let cocking lever snap forward; this must chamber the dummy.
- Charge cocking lever. The first dummy must be extracted and ejected; the second dummy must be fed and chambered.
- Unload rifle.

2.2.6.3. Safety

The selective fire lever must be able to be swivelled to its individual positions and must engage securely in each.

2.2.6.4. Trigger Mechanism

- Disengage the safety.
- With the hammer **cocked**, the trigger must be able to be pulled back against increased pull until the hammer is released.
- With the hammer **uncocked**, the trigger must be able to be pulled back against slight pull.
- Engage the safety.

2.2.7. Trouble-Shooting Chart

Trouble	Cause	Remedy
1. Bolt moves forward without feeding cartridge.	a) Magazine not inserted properly. b) Magazine loose. c) Magazine lips deformed.	a) Insert magazine properly. b) Check magazine catch. If worn, turn in for repair. c) Replace magazine and turn in damaged magazine for repair.
2. Cartridge case not extracted or ejected.	a) Extractor or extractor spring broken. b) Ejector defective. c) Chamber fouled.	a) Turn in for repair. b) Turn in for repair. c) Clean chamber.
3. Cartridge does not ignite.	a) Firing pin broken. b) Firing pin too short. c) Faulty ammunition.	a) and b) Turn in for repair. c) Pull back cocking lever and release to chamber new round.
4. Bolt not completely closed; round not fully fed.	a) Chamber fouled. b) Barrel extension fouled. c) Deformed cartridge. d) Recoil spring worn out.	a) and b) Clean. c) Pull back cocking lever and release to chamber new round. d) Turn in for repair.
5. Rifle fires irregularly.	a) Chamber fouled. b) Magazine not inserted properly. c) Magazine fouled or deformed. d) Defective ammunition.	a) Clean b) Insert magazine properly. c) Insert new magazine; turn in defective magazine for repair. d) Use other ammunition.